



E N G I N E E R I N G M A N U A L

May 2009 • English Version • Issue 3.0



EMERSON
Industrial Automation



Solus
A System Plast Group Company



ENGINEERING MANUAL

Issue 3.0 - May 2009 - English version

The information given here is believed to be reliable, but no representations, guarantees, or warranties of any kind are made as to its accuracy, suitability for particular applications or the results to be obtained there from. The information is based on a laboratory work with small-scale equipment on small samplings of stock material. Particular conditions of use and reasonable lot-to-lot variations can affect performance. Users of our products should make their own tests to determine the suitability of any product for their particular purposes. The products described in this manual are warranted to be free of any defect in material or workmanship when delivered but are otherwise SOLD WITHOUT WARRANTY, EITHER EXPRESSED OR IMPLIED, INCLUDING ANY WARRANTY OF MERCHANTABILITY OR FITNESS FOR A PARTICULAR PURPOSE. Buyer assumes responsibility for loss or damages arising from the use of our products, whether used in accordance with our direction or not, and we shall in no event be liable for incidental or consequential damages. Our sole responsibility shall be to replace any product proved to be defective when delivered. Statements concerning the possible use of our products are not intended as recommendations to use our products in the infringement of any patent. The research efforts to improve the quality and function of our products, permits us to change and replace, without notice, the specification in this manual.

This manual relates to current production. Other information, which may be different from that contained in this publication, must be considered invalid. The right is reserved to carry out modifications rendered necessary by the technical development of System Plast products.

For more technical information, contact our Technical Support.

© **Copyright System Plast Italy 2009**

The contents of this manual are the copyright of the publisher and may not be reproduced (even extracts) unless permission is granted. Every care has been taken to ensure the accuracy of the information contained in this catalogue but no liability can be accepted for any errors or omissions.

**Engineering Manual • 05/2009 • English version
Code N. 22655/003**

Printed in Italy

Engineering manual contents

INTRODUCTION	4	CONVEYOR COMPONENTS	81
		• Speedset	81
		• Roller side guides	91
CHAINS & BELTS		MATERIALS	93
PRODUCTION PROGRAM	7	• Steel chain materials	93
• General selection guidelines	14	• Pin materials for steel & plastic chains	93
CONVEYOR CONSTRUCTION	16	• Plastic chain materials	94
• Conveyor length	16	• Special plastic chain materials	94
• Conveyor speed	16	• Plastic belt materials	95
• Sprocket position for belts	17	• Special plastic belt materials	95
• Sprockets and idler wheels	18	• Pin materials for belts	96
• Curve systems	20	• Rubber materials	96
• Drive construction	24	• Nolu-Clean	97
• Tensioner	25	• Nolu-S	98
• Return part construction	26	• Wear rates comparison chart (NG)	99
• Transfers	28	• HB Pins	100
• Wear strips	39	• RoHs	100
• Calculation	44	• Storage of plastic chains and belts	100
APPLICATIONS	45	• Coefficients of friction	101
• Crate conveying	45	• Chemical resistance	102
• Gripper chains	47	• Application temperatures	104
• Static electricity	48	CLEANING AND MAINTENANCE	105
• Noise reduction	48	• Parameters causing wear	105
• Inclined and declined conveyors	49	• Cleaning instructions	106
• Accumulation	50	• Inspection procedure	108
• Pressureless combiners	51	• Installation procedure	108
• Dry lubrication	52	• Replacement criteria	109
SIDEFLEXING BELTS	58	• Troubleshooting	111
• Powerflex	58		
• FlowFlex	68		
GENERAL CALCULATION	70		
• Product handling	70		
• Bearings and shafts	74		

Quality and Service

When you are looking for a quality conveyor component, look at System Plast.

**Your expectation,
our standard.**

Customers expect the best from System Plast; we are committed to delivering nothing less. In every phase of our operation, from engineering, to production, to sales and assistance, System Plast is committed to complying with the stringent standards of ISO 9001.



We put our Leadership on the line for you.

Our complete range of products combines stainless steel, carbon steel, aluminium and engineered plastics to achieve reliability, superior performance and a compact of design.

As one of the world's leading suppliers of conveyor components, System Plast has a tradition of innovation that dates back to 1985 when we entered into this field. System Plast Components have become the standard of design and performance to a wide range of industries, including conveyor manufacturing, materials handling, power transmission, packaging and many more.

In addition to manufacturing excellence, System Plast has earned a reputation for outstanding customer service, offering a full range of design, custom fabrication and support services.

We hope you will now take a moment to look through this comprehensive manual.

Then, when you are ready to discuss your needs with the nearest System Plast representative, please consult the back cover of this catalog for further details about our sales network.

We are able and eager to assist you setting up a smooth running line.

The components you want, when and how you want them.

System Plast is ready and able to satisfy your needs with quick answers and delivery of standard or custom made products. Our customers around the world know that the shortest distance between a problem and its solution is to call us: innovations, research, engineering and production are always under a strict control to improve our service and products.



Application driven

Focus on application and improvements have been the driving force behind Research and Development at System Plast, the largest global supplier of Conveyor Components.

The most important issues in the beverage and packaging industry are EFFICIENCY, NOISE REDUCTION, HYGIENE, TCO and LUBRICATION REDUCTION. The engineering team of System Plast has taken the issues as a challenge and developed a range of products around them, thus gaining the leading edge on the market by supporting the users in their corporate programs such as TPM, Total Productive Maintenance.

System Plast is a solid partner for the beverage, food and packaging industry. Not only these state-of-the-art developments are important, but just as well that it has the largest available program of conveyor components, chains and belts.

The network of System Plast companies in Italy, Germany, France, UK, Netherlands, USA, Mexico and Brazil, together with the worldwide network of exclusive distributors, services the clients - OEM's as well as end users, including the leading companies in the industry. The people in the field are trained with know-why and know-how and are strongly supported by the engineering team.

Largest range

System Plast delivers the largest range of chains, modular belts, components, bearings, feet.

Conveyor Line: massive, versatile range of conveyor parts like supports, clamps, brackets, guides in plastic and stainless steel; easy combinations for many applications.

Bearing Line: flange bearings in many types and shapes. Completely closed types available for wet environments. Long life versions for ease of maintenance.

Presso Line: the largest range of support feet available. The right choice for any application; from food processing to electrical cabinets.

Modular Plastic Belts: robust design for easy installation and maintenance. Not only the standard range, but special types for difficult products as well. Special materials for dry running, long life and low noise.

SlatBand Chains: chain is the main factor for efficiency of conveyors. System Plast has a wide range of high quality chains in plastic and stainless steel. Special materials for exceptional applications.

Engineering manual for conveyor components

This Engineering Manual has been developed to assist you with specific engineering information when a new conveyor is designed as well as when an existing conveyor is going to be modified. Terms like TPM (Total Productive Maintenance) and SMED (Single Minute Exchange of Dies) are getting more and more important. With the right choice of chains and components you can design your conveyors to meet these principles. A large part of our program suits these principles.

With this manual we intend to create some "CONVEYOR AWARENESS". As you will notice, most attention will be given to the construction details for chains and belts, because these are the 'moving parts' in a conveyor and therefore more critical when it comes to construction details. We also emphasize on guides as together with the chains and belts, these are in direct contact with the customer's product and therefore of utmost importance. The right choice of type, style and material of the side guides can make the difference between a medium and a high production efficiency of a filling line.

For additional data and information about technical details of our products please refer to:



- **Conveyor Chains & Belts catalogue**

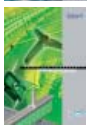

- **Conveyor Components catalogue**



- **Leveling pads catalogue**



- **Bearing supports catalogue**



- **Calculation program**





















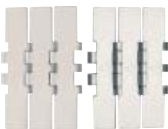

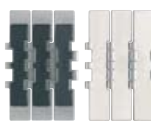

Contact us

To contact your local Technical Support check our website www.systemplast.com or send an email to: technicalsupport@systemplast.com



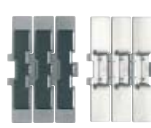







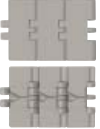

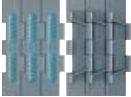



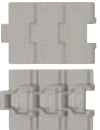





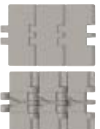



We cannot take responsibility for imperfections, damage or injuries due to wrong conveyor design, poor installation or improper use of our products made with or without reference to the information in this manual.

We appreciate your suggestions to improve this Engineering Manual.

STEEL CHAINS















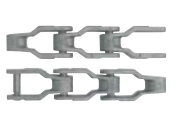







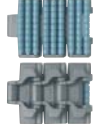

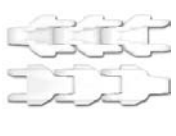



STRAIGHT		SIDEFLEXING			
Flat top	Rubber top	Flat top	Plate top (base rollers chain)	Rubber top	Gripper
 812 - 815	 815 VG	 881	 1874	 881 VG	 1874 GV
 SPEED LINE 812L - 815L	 815 VG MINI	 881O		 881 TAB VG	
 800 - 802 - 805	 815 TAB VG	 881 TAB		 8857 M VG	
 8157	 805 VG	 881O TAB		 881 MO VG	
 515	 8157 VG	 881 M - 881 MO			
	 8157 TAB VG	 SPEED LINE L 881 MO			
		 8857 M			
		 8857 TAB			

PLASTIC CHAINS

STRAIGHT				SIDEFLEXING	
Flat top	Plate top (base rollers chain)	Rubber top	LBP	Flat top	Plate top (base rollers chain)
 820 - 820 J	 843	 821 VG	 LBP 821	 879 - 880	 1843
 828	 845	 831 VG	 LBP 8257	 879 J - 880 J	 1863
 831	 863	 8257 VG	 LBP 831	 879 TAB - 880 TAB	 1873
 SK 38				 879 M - 880 M	 1883
 821				 878 TAB	
 8257				 882 BEVEL	
				 882 TAB	
				 882 M	

PLASTIC CHAINS

SIDEFLEXING

Rubber top	LBP	Gripper	Multiflex	Multiflex	Crate conveyor
 878 TAB VG	 LBP 878 TAB	 878 TAB GS	 1700 - 1702	 7000 - 7000 TAB	 CC 600 - CC 600 TAB
 879 TAB VG	 LBP 879 M	 1873 GS	 HMGK 50 FN HMGK 50	 7001 - 7001 TAB	 CC 600 P
 879 M VG	 LBP 882 TAB		 HMGK 50 MS	 7005 - 7005 TAB	 CC 600 TAB P
 882 TAB VG	 LBP 882 M		 HMGK 50 P		 CC 600 F - CC 631 TAB
 882 M VG			 1701 TAB 1701 TAB OP		 CC 1400
 1873 VG			 1701 TAB OP M 1702		 CC 1400 TAB
			 HMGK 50 - TAB P		 CC 1431 TAB
			 HMGK 50 H		
			 HMGK 50 TAB H		

STRAIGHT RUNNING BELTS - 8.7 mm thick







3/4 INCH PITCH

1 INCH PITCH

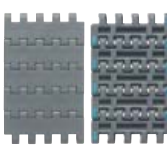

Imperial w.

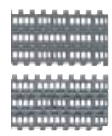
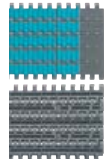
Metric widths





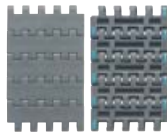
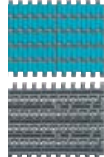
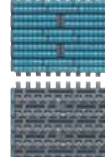
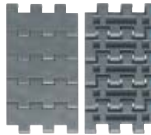
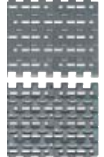
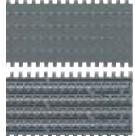
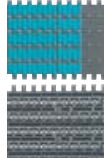





Imperial widths

Flush grid	Flat top	Flush grid	Grip belt	LBP belt	Flat top	Perforated top
						
One track belts series 2190	One track belts series 2250	One track belts series 2250	Modular belts series 2250			
						
Modular belts series 2190	Modular belts series 2250	Modular belts series 2250	Belts with side indent series 2250			
						
	Belts with transfer wing series 2250	Belts with transfer wing series 2250				

HEAVY DUTY 12.7 mm thick - 1 inch pitch









						
	One track belts heavy duty 2251		Modular belts heavy duty 2251	Modular belts heavy duty 2251	One track belts heavy duty 2252	Modular belts heavy duty 2252
						
	Modular belts heavy duty 2251		Belts with side indent heavy duty 2251		Modular belts heavy duty 2252	
						
	Belts with transfer wing heavy duty 2251					

CHAINS & BELTS PRODUCTION PROGRAM

SIDEFLEXING BELTS		SIDEFLEXING CHAINBELTS	
½ INCH PITCH	1 ¼ INCH PITCH	1 INCH PITCH	
Metric widths	Metric widths	Metric widths	Metric widths
<p>Flat top</p>  <p>Magnetic system 2120 M One track</p>	<p>Flush grid</p>  <p>Modular belts series Standard 2351</p>	<p>Flat top</p>  <p>series 2550 M FT 8.7 mm thick</p>	<p>Flush grid</p>  <p>series 2550 M FG 8.7 mm thick</p>
	<p>Flush grid</p>  <p>Modular belts series Heavy Duty 2451</p>	<p>Flat top</p>  <p>series 2260 M FT 8.7 mm thick</p>	
	<p>Flush grid</p>  <p>Modular belts series Small Radius 2551</p>	<p>Flat top</p>  <p>series 2250 TAB FT 8.7 mm thick</p>	
	<p>Flush grid</p>  <p>Modular belts series Heavy Duty Small Radius 2651</p>	<p>Flat top</p>  <p>series 2251 M FT 12.7 mm thick</p>	
		<p>Flat top</p>  <p>series 2251 TAB FT 12.7 mm thick</p>	



General selection guidelines

Product	Preferred options	Other options	Lubrication
 <p>Cans (2-piece, aluminium)</p>	Flush grid belt e.g. 2250 FG, PowerFlex	Plastic chain e.g. 828, 880M	- Lubrication is recommended. - So called "half-wet" conditions should be avoided in order to improve service life of chains/belts and components. In such cases aluminium-oxide acts abrasively.
 <p>One-way glass</p>	SS chain e.g. Speed-Line, Speed-Line HB Flat top belt e.g. 2250 FT, PowerFlex	Plastic chain e.g. 828, 880M	- Lubrication is required for all sections with SS chains.
 <p>Return glass</p>	SS chain e.g. Speed-Line, Speed-Line HB		- Lubrication is required.
 <p>One-way PET</p>	Flat top belt e.g. 2250 FT, 2120 FT PowerFlex, FlowFlex	Plastic chain e.g. 828, 880M	- Lubrication is recommended. So-called "dry lubrication" is commonly used.
 <p>Return PET</p>	SS chain e.g. Speed-Line, Speed-Line HB Flat Top belt e.g. 2250 FT, PowerFlex	Plastic chain e.g. 828, 880M	- Lubrication is required for all sections with SS chains.
 <p>Crates</p>	SS chain e.g. SSE 815 K750 SSE 8157 K750 VG, HB CC chain e.g. CC 600		- Lubrication is required for all sections with SS chains.
 <p>Boxes</p>	Flat Top belt e.g. 2250 FT, 2251 FT, 2120 FT, LBP, VG, PowerFlex, FlowFlex	Plastic chain e.g. 828, 880M	- In most cases lubrication is not admitted.
 <p>Shrink-wrapped products</p>	Flat Top belt e.g. 2251 FT, VG, LBP 2120 FT, VG, LBP PowerFlex Plastic chain e.g. 8257, 882M, LBP, VG		- In most cases lubrication is not admitted.

Materials	Remarks
<ul style="list-style-type: none"> - NG material is recommended for sections with abrasive conditions. - CR material is recommended for sections where higher friction is required (e.g. twister). - LF material is generally suitable for well lubricated sections. 	<ul style="list-style-type: none"> - TransferWing version is commonly used for 90 degree transfers between conveyors.
<ul style="list-style-type: none"> - Extra Plus material is recommended. - Standard material can be used on slow speed and low load sections. - HB pins are recommended in order to extend service life of chains. - NG material is suitable for dry-running sections (e.g. depalletizer). 	<ul style="list-style-type: none"> - K330 width offers reduced gap between adjacent chains and improves product stability particularly in side-transferring sections.
<ul style="list-style-type: none"> - Extra Plus material is recommended. - Standard material can be used on slow speed and low load sections. - HB pins are recommended in order to extend service life of chains. 	<ul style="list-style-type: none"> - K330 width offers reduced gap between adjacent chains and improves product stability particularly in side-transferring sections.
<ul style="list-style-type: none"> - LF material is suitable with lubrication. - NG material is recommended for dry run as well as for sections where chemical attack must be expected (e.g. peracetic acid). 	<ul style="list-style-type: none"> - Real dry operation (no lube) is possible in all sections where product handling permits. NG is recommended, then. - Cleaning is of major importance regarding service life of chains/belts/ components. - 1/2" belts (e.g. 2120, FlowFlex) offer short head-to-tail transfers.
<ul style="list-style-type: none"> - Extra Plus material is recommended. - HB pins are recommended in order to extend service life of chains. - High Friction (rubber top) chains are used for inclined conveyors. - NG material is recommended for abrasive conditions. - LF material for standard conditions. 	<ul style="list-style-type: none"> - Returnable PET bottles require in principle the same conveyor design as glass bottles. Product handling is similar. Abrasive conditions are nearly the same. - K330 width offers reduced gap between adjacent chains and improves product stability particularly in side-transferring sections.
<ul style="list-style-type: none"> - Extra Plus material is recommended. - HB pins are recommended in order to extend service life of chains. - High Friction (rubber top) chains are used for inclined conveyors. - NG material is recommended for abrasive conditions. - LF material for standard conditions. 	<ul style="list-style-type: none"> - CC chains are recommended, if lubrication is not admitted.
<ul style="list-style-type: none"> - LF material is suitable in most cases. - NG material is recommended for abrasive conditions. - LBP chains/belts are recommended for accumulation sections. - High Friction (rubber top) chains/belts are used for inclined conveyors 	<ul style="list-style-type: none"> - 1/2" belts (e.g. 2120, FlowFlex) offer short head-to-tail transfers.
<ul style="list-style-type: none"> - LF material is suitable in most cases. - NG material is recommended for abrasive conditions as well as for high speed and/or high load. - LBP chains/belts are recommended for accumulation sections. - High Friction (rubber top) chains/belts are used for inclined conveyors. 	<ul style="list-style-type: none"> - 1/2" belts (e.g. 2120) are commonly used for all pack arrangement sections. - 1"- Heavy Duty belt (e.g.2251) offers long durability under high load conditions.

Conveyor length

Conveyor length depends on

- Chain/belt type
- Lubrication
- Product
- Load
- Etc.

Type	Max. advisable length [m]
Stainless steel, straight	Approx. 15
Plastic chains, straight	Approx. 12
Stainless steel, sideflexing	Approx. 9 - 12
Plastic chains, sideflexing	Approx. 9 - 12

These are indicative figures.

In any case it is recommended to double check the conveyor length by calculating the resulting chain pull.

A phenomenon called **slip stick effect** occurs unpredictably. It depends on speed, load, construction and lubrication. Pulsating dynamic forces are the result and affect the service life of all components of a conveyor. More importantly it influences product handling in a negative way.

Long conveyors should be avoided in such cases.

Long conveyors result in high chain load, which affects many components of the conveyor and their wear life.

Conveyor speed

Maximum speed in m/min

Type	Lubrication		
	Dry	Water	Water & soap
Stainless steel, straight	Not recommended	70	130
Stainless steel, Magnet System, TAB	Not recommended	40	130
Plastic chains, straight	80	100	150
Plastic chains, sideflexing, Magnet System, TAB	50	90	130
Plastic belts, straight	80	100	150

Under abrasive or high load conditions the maximum speed is reduced.

Higher speed causes higher wear in any case.

For higher wear resistant materials contact our technical support.

Sprocket position for belts

Nominal belt width		Recommended number of sprockets/ idler wheels
Series 2120, 2250, 2251	Series 2121, 2190, 2252	
85	3" (76.2 mm.)	1
170	6" (152.4 mm.)	2
255	9" (228.6 mm.)	3
340	12" (304.8 mm.)	4
425	15" (381 mm.)	5
510	18" (457.2 mm.)	6
595	21" (533.4 mm.)	7
680	24" (609.6 mm.)	8
765	27" (685.8 mm.)	9
850	30" (762 mm.)	10
935	33" (838.2 mm.)	11
1020	36" (914.4 mm.)	12
1105	39" (990.6 mm.)	13
1190	42" (1066.8 mm.)	14
1275	45" (1143 mm.)	15
1360	48" (1219.2 mm.)	16
1445	51" (1295.4 mm.)	17
1530	54" (1371.6 mm.)	18
1615	57" (1447.8 mm.)	19
1700	60" (1524 mm.)	20
ect.		

Fix only one sprocket (centre sprocket), if the belt is running without positioners or any other lateral guide.

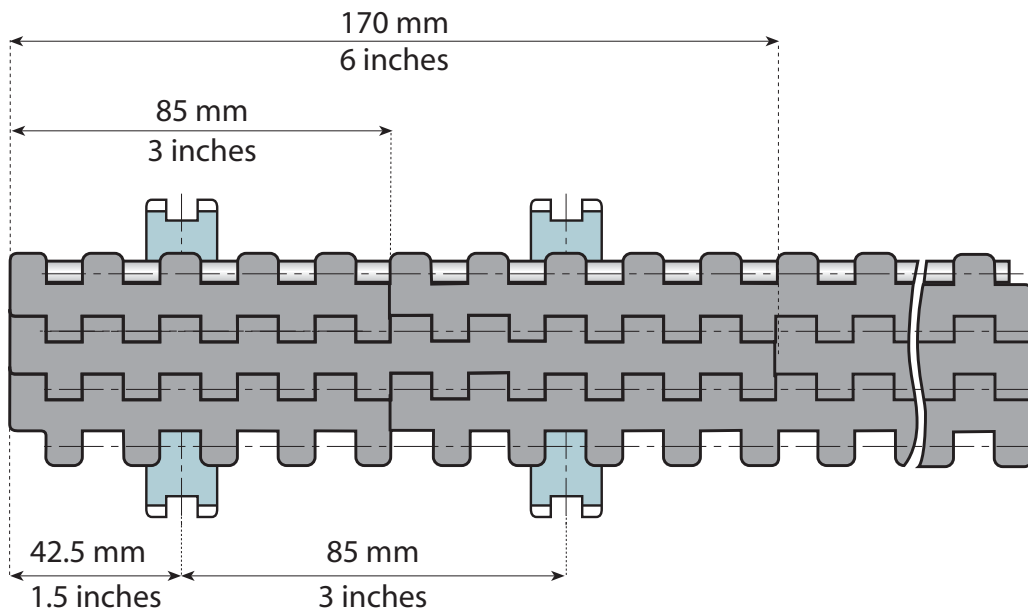

Sprockets and idler wheels

For detailed information about the different types of sprockets, please refer to the chain/belt catalogue.

For the positioning of the sprockets, the horizontal and vertical position relative to the shaft is important for both sprocket and idler to ensure a smooth running of the chain at minimum noise level.

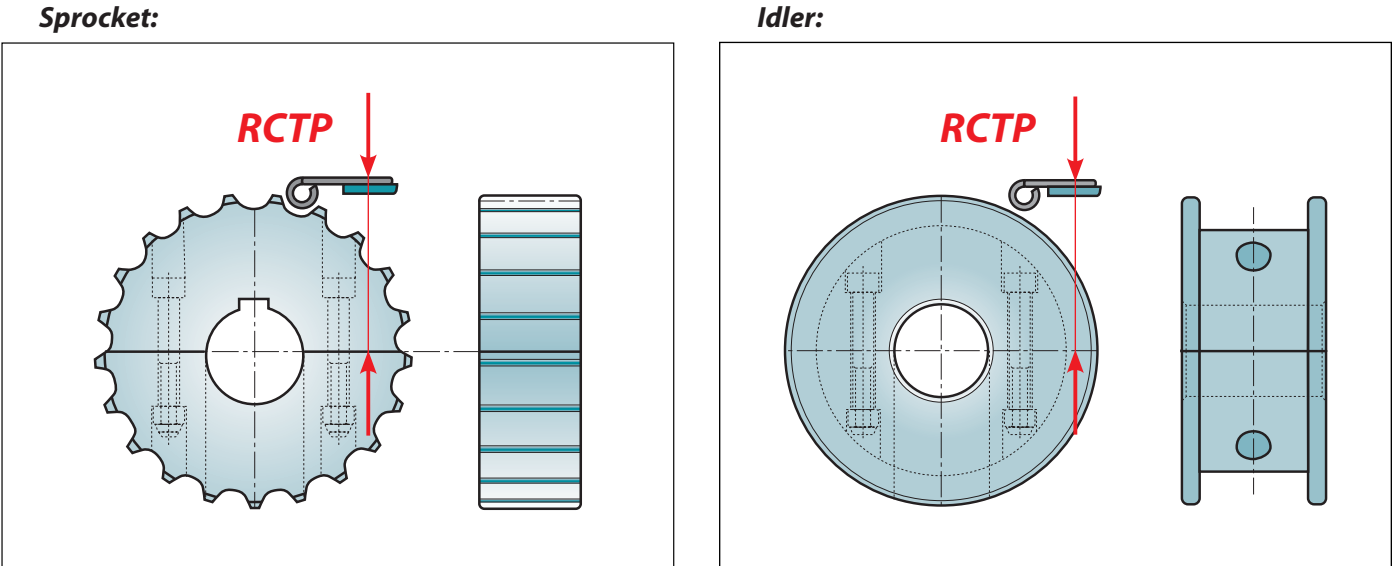

When matching sprockets for chains to sprockets for belts, the corresponding number of teeth can be chosen depending on the dimension centre of shaft to the top of the chain/belt (RCTP) or the top of the wear strip (S).

In the below table matching sprockets can be found below each other.

Chain type			Top of chain / belt matching approximately								
815	Z	teeth number		17	19	21	23	25		27	29
	H	pitch diameter		105.47	117.34	129.26	141.21	153.21		165.20	177.24
	RCTP	top of chain to center of sprockets		59.34	65.27	71.23	77.21	83.21		89.20	95.22
820	Z	tooth number		17	19	21	23	25		27	29
	H	pitch diameter		105.47	117.34	129.26	141.21	153.21		165.20	177.24
	RCTP	radius top of chain to center of sprockets		59.94	65.87	71.83	77.81	83.81		89.80	95.82
2250	Z	teeth number	12	14	16	18		20			
	H	pitch diameter	98.14	114.18	130.20	146.27		162.37			
	RCTP	top of chain to center of sprockets	53.42	61.44	69.45	77.49		85.54			
880	Z	tooth number			9	10	11	12			
	H	pitch diameter			111.40	123.3	135.20	147.20			
	RCTP	radius top of chain to center of sprockets			63.25	69.20	75.15	81.15			
2120	Z	teeth number	24	28		36	38	40			
	H	pitch diameter	97.30	113.43		145.72	153.78	161.85			
	RCTP	top of chain to center of sprockets	53.00	61.07		77.21	81.24	85.28			

Sprocket:

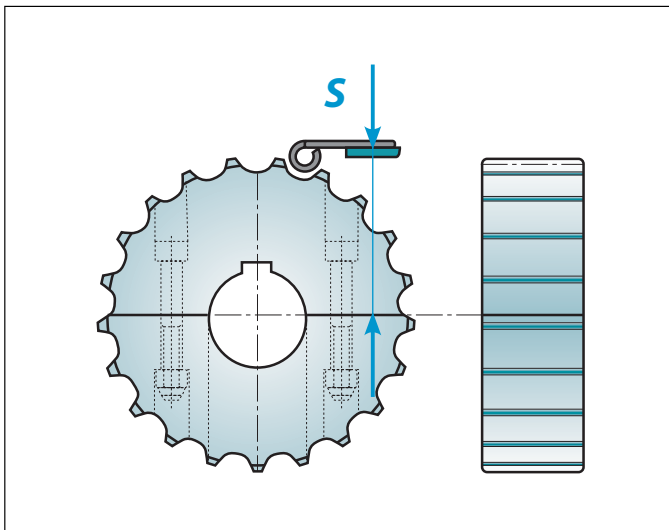

Idler:

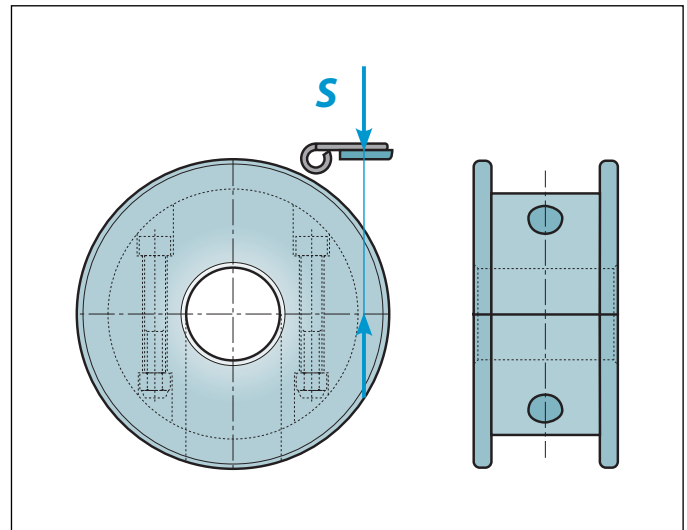

Chain type			Top of wear strip matching approximately								
815	Z	teeth number		17	19	21	23	25		27	29
	H	pitch diameter		105.47	117.34	129.26	141.21	153.21		165.20	177.24
	S	radius top of wear strip to center of sprockets		56.24	62.17	68.13	74.11	80.11		86.10	92.12
820	Z	tooth number		17	19	21	23	25		27	29
	H	pitch diameter		105.47	117.34	129.26	141.21	153.21		165.20	177.24
	S	radius top of wear strip to center of sprockets		55.94	61.87	67.83	73.81	79.81		85.80	91.82
2250	Z	teeth number	12	14		16	18		20		
	H	pitch diameter	98.14	114.18		130.20	146.27		162.37		
	S	radius top of wear strip to center of sprockets	44.72	52.74		60.75	68.79		76.84		
880	Z	tooth number			9	10	11	12			
	H	pitch diameter			111.40	123.3	135.20	147.20			
	S	radius top of wear strip to center of sprockets			59.25	65.20	71.15	77.15			
2120	Z	teeth number	24	28			36	38	40		
	H	pitch diameter	97.30	113.43			145.72	153.78	161.85		
	S	radius top of wear strip to center of sprockets	44.30	52.37			68.51	72.54	76.58		

Shafts:

Stainless steel is recommended in every case.

Sufficient hardness (> 25 HRC) as well as smooth surface (<0.6 μm) is recommended.

For chains usually round shafts are used, for belts round or square shafts.

Shaft tolerance is usually H7

Key seats are made according to DIN 6885

Curve systems

A chain has to be kept in a curve to avoid the chain to jump up from the curve. There are 3 different curve systems commonly in use:

Bevel:

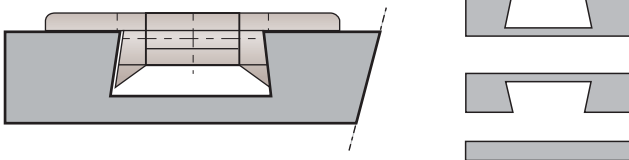

Tab:

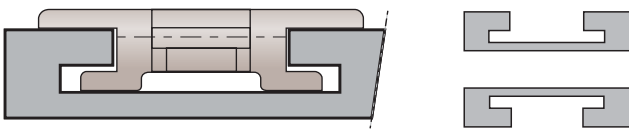

Magnetic:

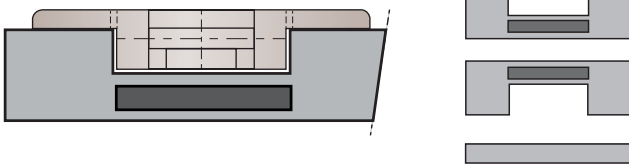

There can be different arguments when choosing a curve system:

- cost
- cleanability
- easy maintenance
- security
- possible presence of foreign particles
- abrasive conditions
- inspector demands
- side transfers
- etc.

Comparison of corner systems:

	Bevel	TAB	Magnetic
Secure chain retention:	+	+++	++
Support in return part:	-	+	+
Chain can be lifted for cleaning:	+	-	+++
Jamming due to foreign particles:	+	-	++

Especially with instable products and a multiple strand situation Bevel and Tab have a disadvantage: the link is lifting somewhat in the curve creating a 'step' between the individual strands:

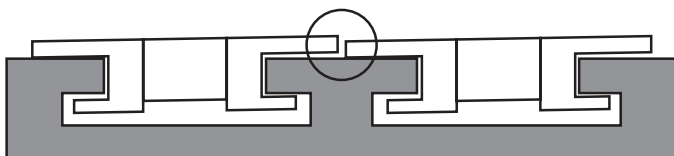

With the Magnet system the links remain flat on the curve:

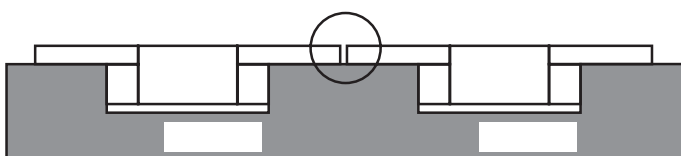

Load on curves:

When designing a layout, the curves tend to be the limiting factor. The curve adds significantly to the chain pull. The chain pull at the end of the curve is the curve factor times the chain pull at the beginning of the curve. The curve factor 'f' is depending on the angle of the curve and the friction between chain and curve (for further calculations we refer to our calculation program):

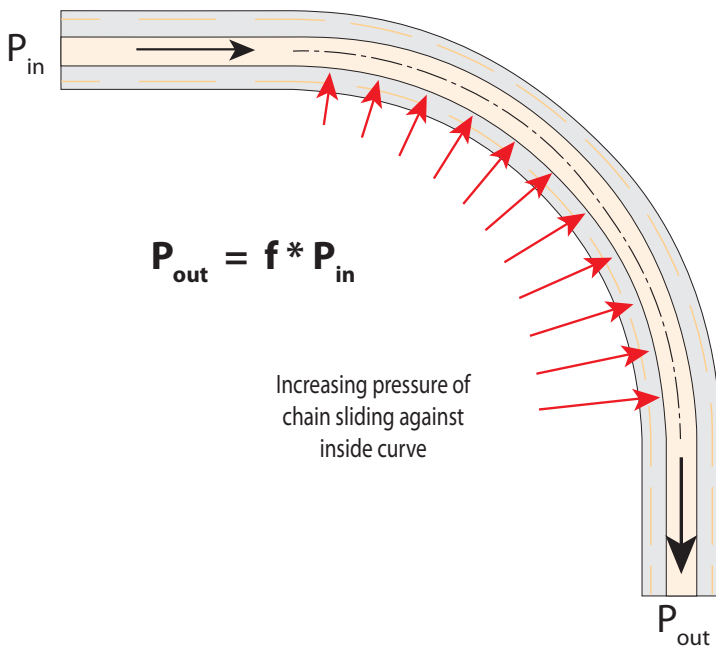

Because of this curve factor it's generally better to position a curve close to the idler end rather than close to the drive end. Then the curve adds relatively less chain pull.

In general we recommend to keep the total curve angle in a conveyor below 180°.

The pressure on the inside of the curve increases through the curve and together with the speed of the chain it generates heat. The maximum allowable Pressure and Velocity (speed) together is called PV limit. This is an important factor next to the max allowable chain pull. The generated heat will warm up the curve material and when it gets too warm, it will become softer and wears out fast.

Use the System Plast calculation program to check the load and PV limit in any case.

To maximise the PV limit, System Plast has developed some special curve materials:

Nolu-S:

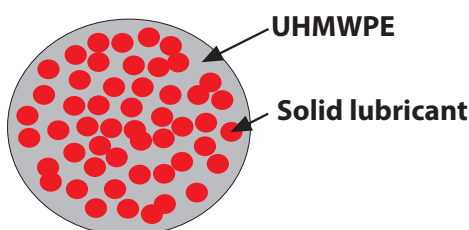

Nolu-S is a unique compound of UHMWPE and a solid lubricant. Nolu-S drastically reduces the coefficient of friction whilst maintaining the characteristics of UHMWPE. Nolu-S also has a better thermal conductivity compared to UHMWPE.

EXTRA curve:

In an EXTRA curve a profiled stainless steel strip is mounted on the inside of the curve.



Stainless steel strip

The profiled structure of the stainless steel strip dissipates the heat, has a better resistance and reduces the friction than standard UHMWPE.

Especially in running dry applications with plastic chains, the EXTRA strip reduces the wear because it conducts the heat from the curve much better than plastic material.

The EXTRA execution is also available for a TAB curve and for Powerflex belts.



Installation:

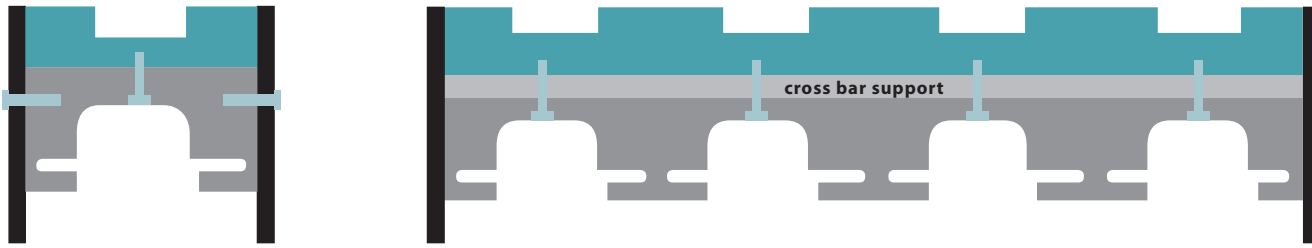

Curves are generally mounted between stainless steel 'side skirts' and fastened with screws or with bolts and threaded inserts which are optional with the curves.

For curves wider than 3 tracks we recommend to use cross bar supports, to avoid bending of the curve under load.

For a trouble free infeed of the chains, Return Guide Shoes are recommended to be mounted at the infeed of the return part of the curve:

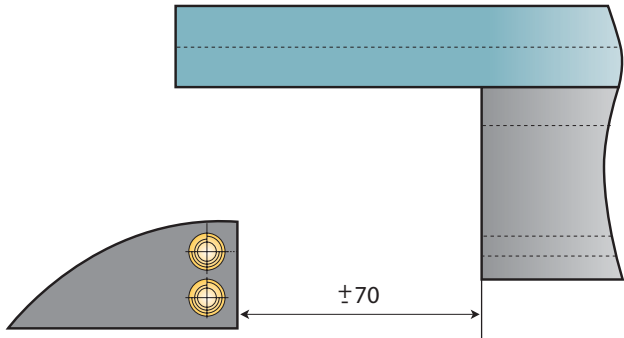

In case of staggered return, position return guide shoe level to top track:

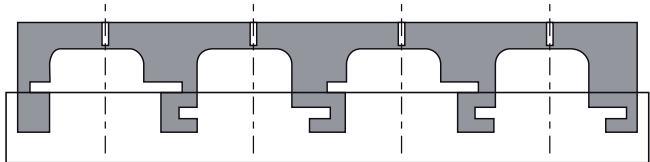

Self cleaning curve:

A special execution of a magnetic curve in circumstances with higher demands on hygiene is the self cleaning curve:

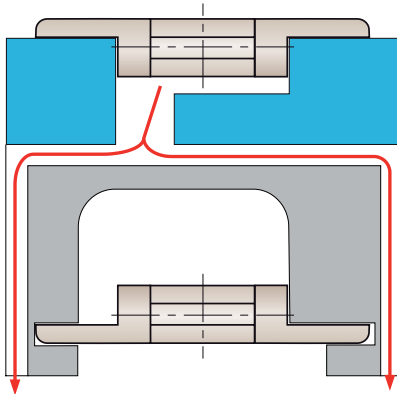

- This curve is:
- self draining
 - no recontamination in return part
 - installation of nozzles possible.

Drive construction

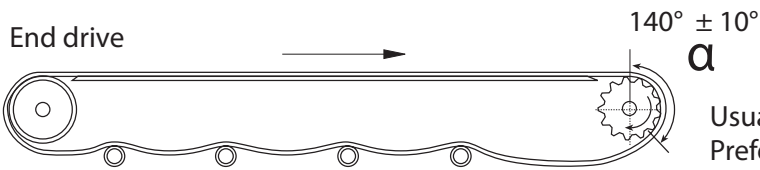

Usually used for mono-directional applications. Preferred running direction of chain has to be considered.

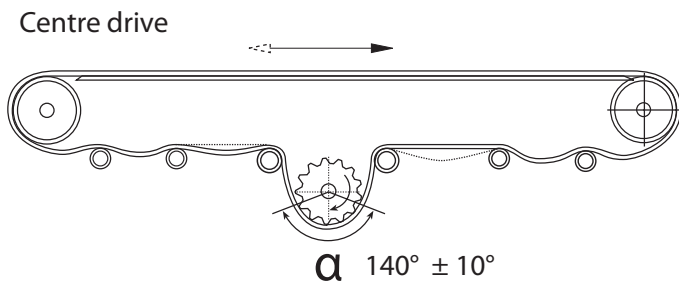

Usually used for bi-directional applications or when space at the end of the conveyor for a drive construction is limited. Commonly used for off line accumulation tables. Chains without preferred running direction are recommended.

Wrap around angle α :

Recommended angle on sprockets is $140^\circ \pm 10^\circ$.

Too small angles may result in chain/belt jumping on the sprocket.

Too big angles may result in chain/belt not releasing safely from the sprocket.

Catenary sag:

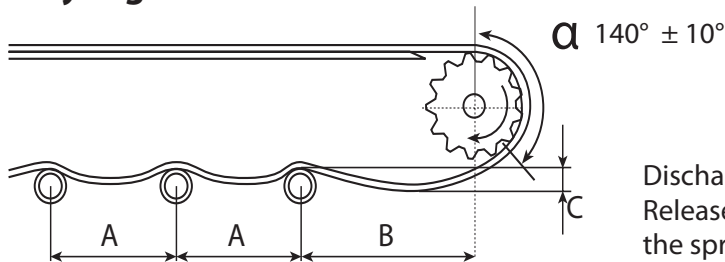

Discharges the chain load. Releases chain properly from the sprocket.

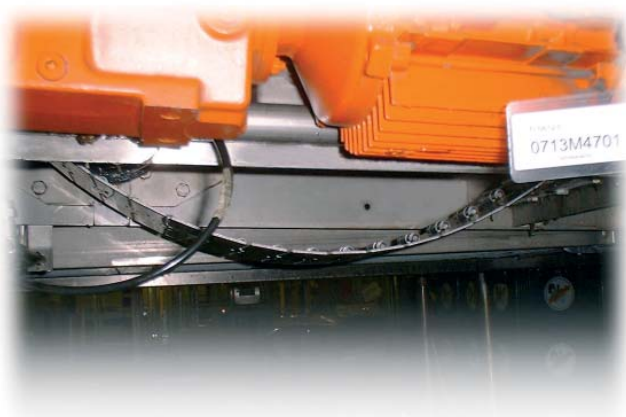

Typical catenary sag

Recommended dimensions.

	A mm	B mm	C mm
Chains	400-550	500-900	50-125
LBP chains	400-550	600-900	50-150
Belts	500-700	600-900	50-125

Speed, start-up frequency and drive control must be considered for the design of catenary sags. Catenary sag should be checked and adjusted regularly due to chain elongation.

In any case the length of the catenary sag (B) must be longer than dimension A.

Tensioner

If no proper catenary sag construction is possible, e.g. in case of insufficient space, tensioners are used.

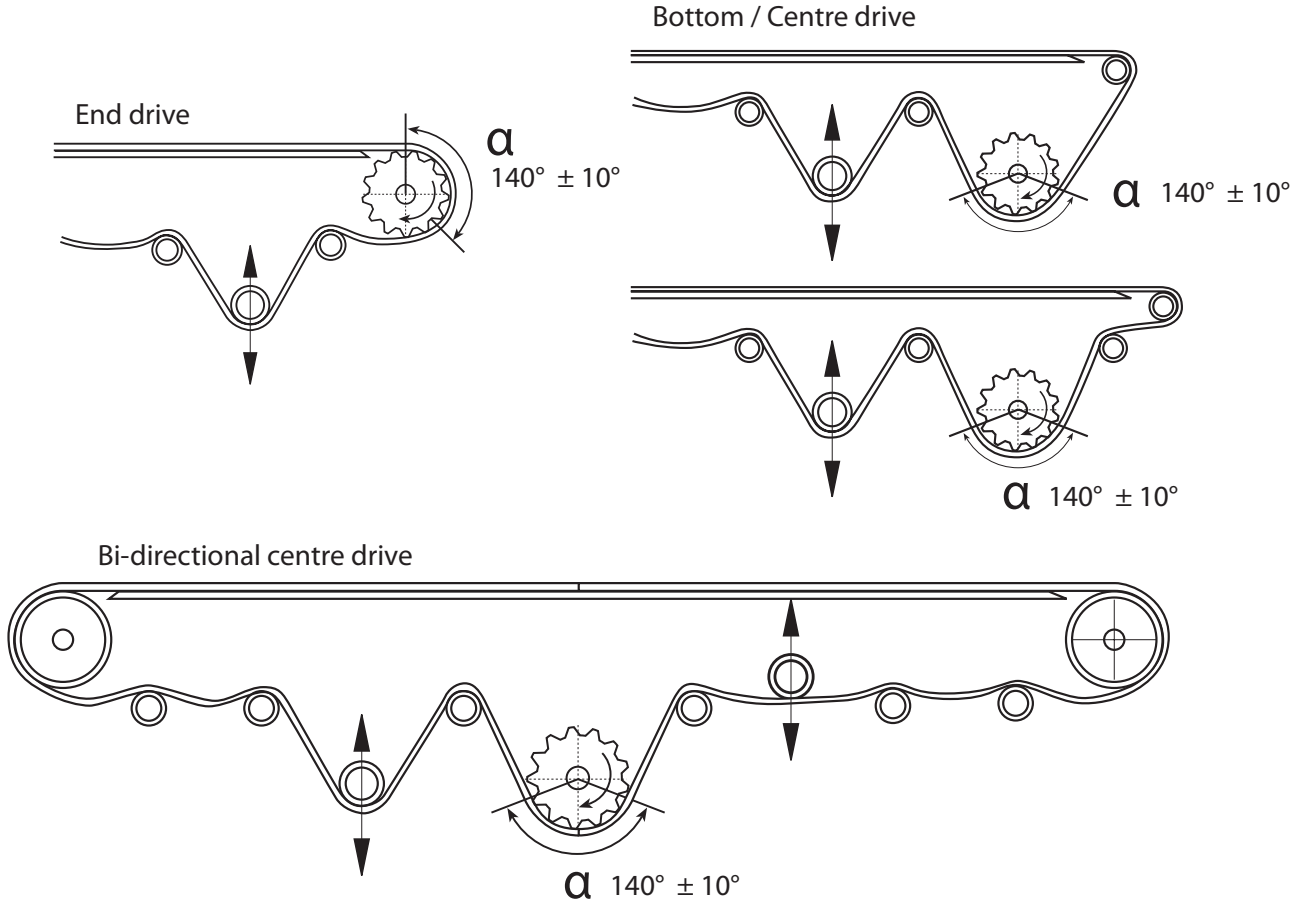

Gravity take up: 5-10 Kg per meter of belt width.
1-2 Kg per chain strand.

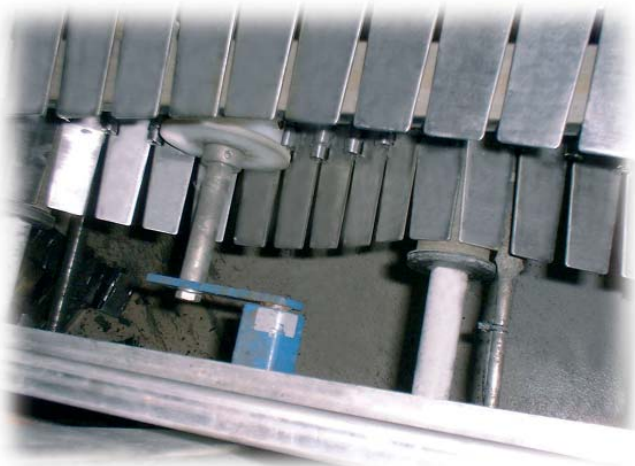

Common tensioner

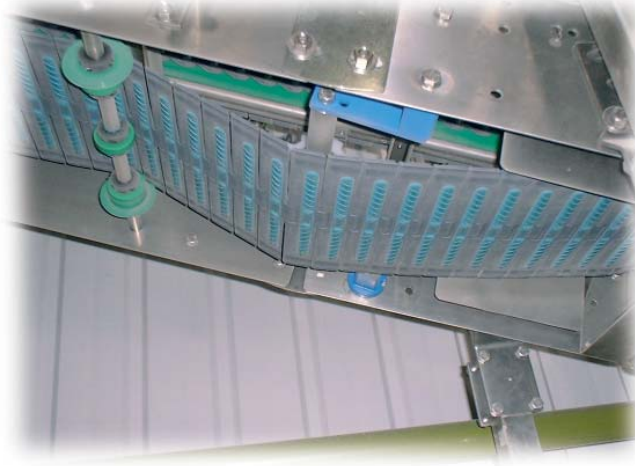

Common tensioner

Return part construction

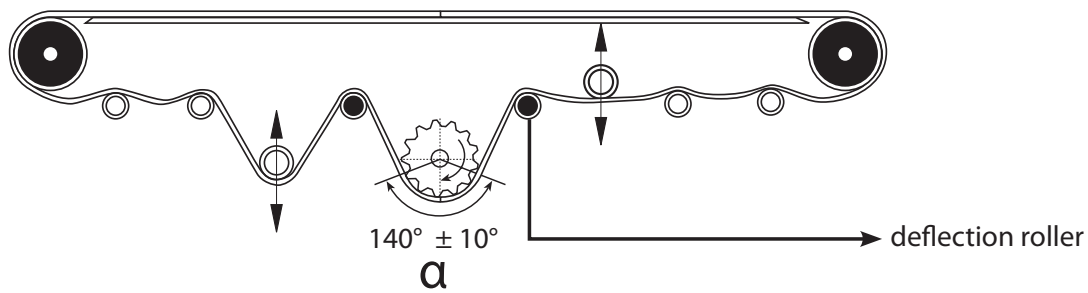
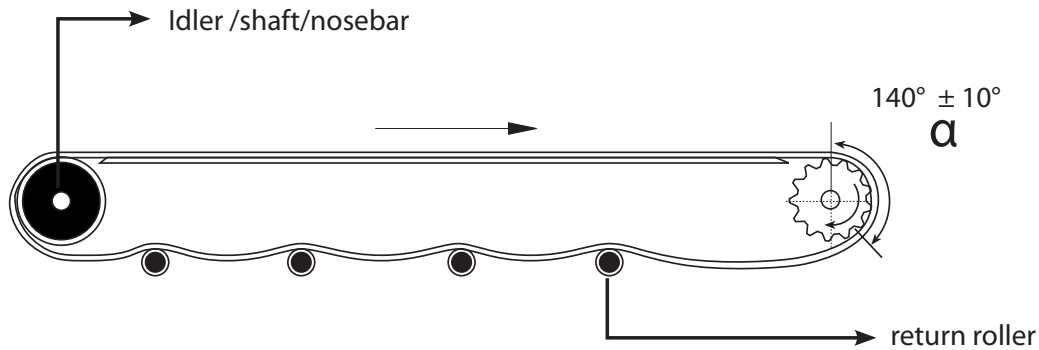

Recommended roller diameters:

Roller type	Chains (mm)		Belts (mm)				
			1/2" inch pitch		3/4" inch pitch	1" inch pitch	
	LBP	Other versions	LBP	Other versions	Other versions	LBP	Other versions
Idler	> 100		> 19		> 40	> 50	
Return	Guide shoes	> 50	Guide shoes	> 50	> 50	Guide shoes	> 50
Deflection	> 270	> 50	> 270	> 50	> 60	> 270	> 80



Rotating rollers:

- Free rotation required.
- Big diameters recommended.
- Reduced wear of chain/belt.
- Debris is ejected.
- Reduced noise with O-ring/rubber coating.
- Improved grip with rubber coating.
- Improved wear resistance and further improved grip with urethane coating.
- Machined solid versions for heavy duty and hygienic applications.



Guide shoes:

Radius = 270 mm.

- Suitable for LBP chains/belts.
- Debris is ejected.
- Low noise version available.



Wear strips "serpentine system":

UHMWPE recommended.

- Reduced noise.
- Full support.

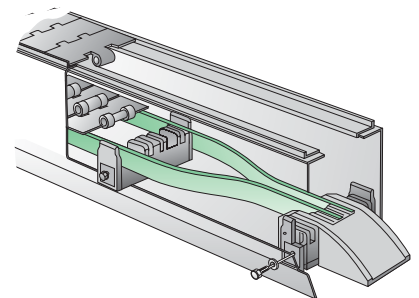

Chains/belts with high friction surface:



Transfers

There are different ways of transferring products from one conveyor onto the next. This is depending on lay out, available space, type of product, lubrication situation, self clearing or not, etc.

Side transfer (see below):



90° transfer (see page 31):

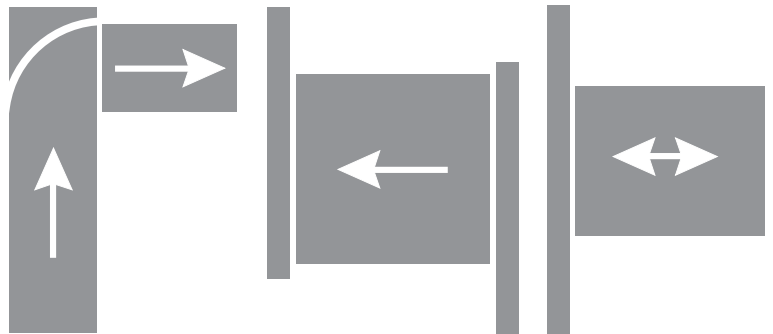

Head to tail transfer (see page 33):

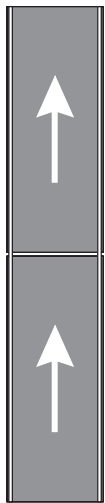

The most common transfer is the **SIDE TRANSFER**.

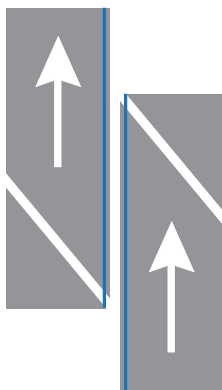

In this situation the products are pushed sideways onto the next conveyor by the side guide. Consequently there's force on the chain/belt square to the travel direction. Therefore the chain/belt needs to be guided sideways. With chains this can be done against the side of the hinge. With belts this can be done with positioners.

Options for positioners:

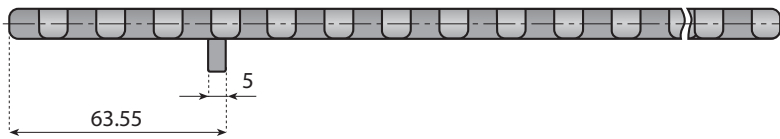

Example 2250 FT P1

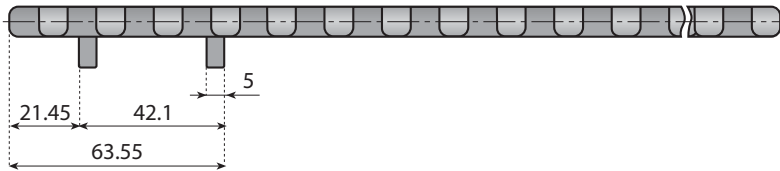

Example 2250 FT P2

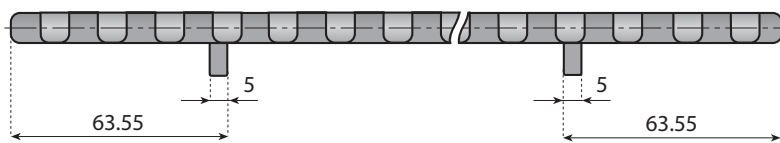

Example 2250 FT P2 B

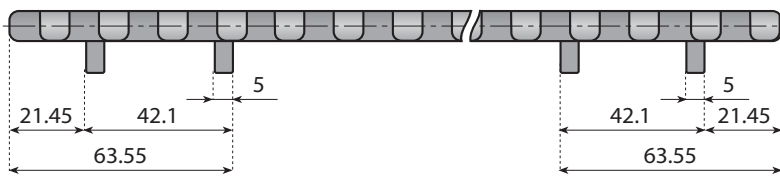

Example 2250 FT P2 BD

The blue line in the principle sketch on the previous page shows that the positioners in this situation should be at the transfer side. Then the position of the belt (and thus the gap between the two belts) at the transfer is fixed. Possible thermal expansion of the belt will be absorbed at the opposite side of the belt.

Thermal expansion factors (f) are:

- LF (Acetal): ~ 0.12 mm/m/°C
- NG (New generation): ~ 0.13 mm/m/°C
- PP (Polypropylene): ~ 0.15 mm/m/°C

Calculation:

$$\text{Expected expansion [mm]} = W * \Delta T * f$$

$$W = \text{belt width [mm]} / 1000$$

$$\Delta T = \text{temperature difference ([}^\circ\text{C]} - 21^\circ\text{C)}$$

To be able to absorb the thermal expansion the belt needs some clearance on the side. Depending on the expected temperature difference the structure should be wide enough to make sure the belt will not get stuck at high temperatures or, in case of low temperatures, be small enough to still support the belt at low temperatures.



The total clearance to be considered is (indicative values):

- 4 mm for belt width < 500 mm
- 6 mm for belt width 500 to 1500 mm
- 8 mm for belt width 1500 to 3000 mm
- 10 mm for belt width > 3000 mm

The standard production tolerance on the width for belts made in polyacetal is +0 / - 0,5%.

Inliners:

Use a K330 (83,8mm) wide chain on an inliner with pitch 85 mm to reduce the gap between the strands to a minimum. Also use the top of the range chain/belt to secure a smooth transfer over the inliner:

For stainless steel chains: SPSL series

For plastic chains: series 828 in NG material

For plastic belts: series 2120 in NG material.

STM module:

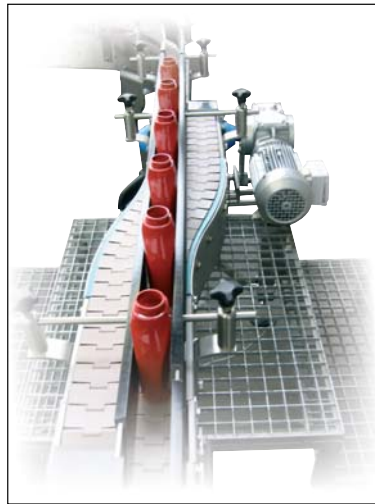

Instead of the products shifting sideways onto the next chain, the chain is shifting from underneath the products. The side guide remains straight and the pressure on the products is less. This transfer system always requires a side flexing chain.

Depending on the construction a standard or a compact version can be used:

Standard Version (view from above)

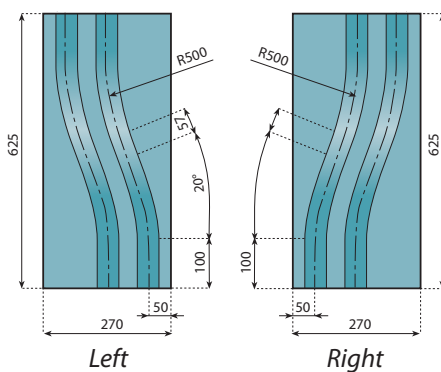

Compact Version (view from above)

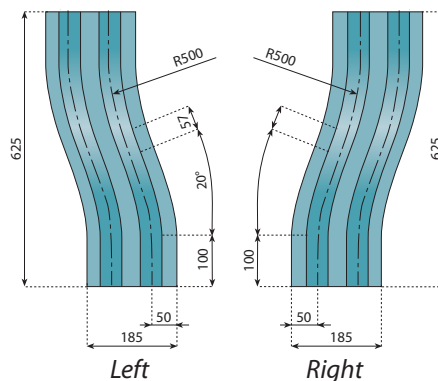

Please note that each STM module adds 40° curve to the conveyor. So if an STM module is used on both idler as well as drive end, a total of 80° is added. This should be taken into consideration when calculating the load and PV limit.

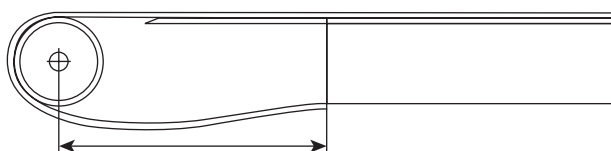

Normal catenary dimensions
see page 24

Important: also when a STM block is used the drive end needs a proper dimensioned catenary sag. This means that the drive shaft should be positioned at enough distance from the STM.

90° transfer:

To make a 90° turn in the layout in a small space a **SQUARE TRANSFER** can be used.

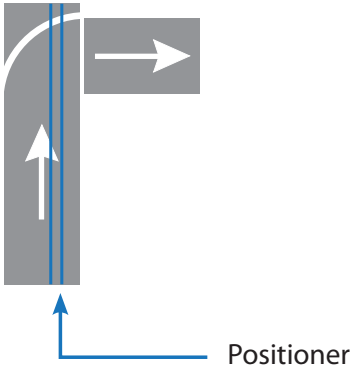

The transfer can be done with a dead plate but the line can be made self clearing by using the System Plast Active Transfer Wing:

Active Transfer Wings are available as:

Single track version or,

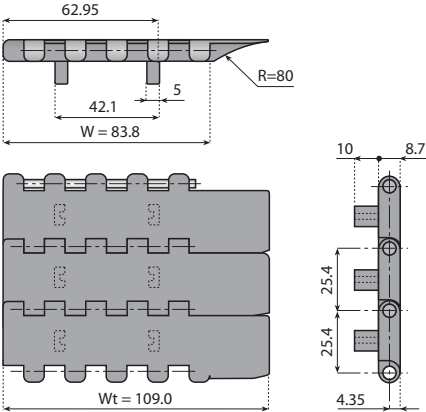

Connected to full width belt

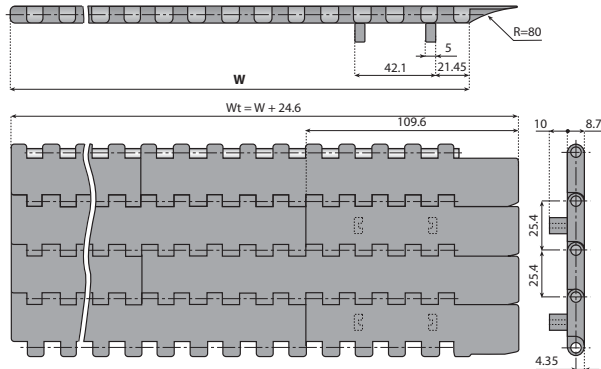

The single track version can be positioned at the transfer section (only the last part of the conveyor) and driven by the same motor as the feeding conveyor:

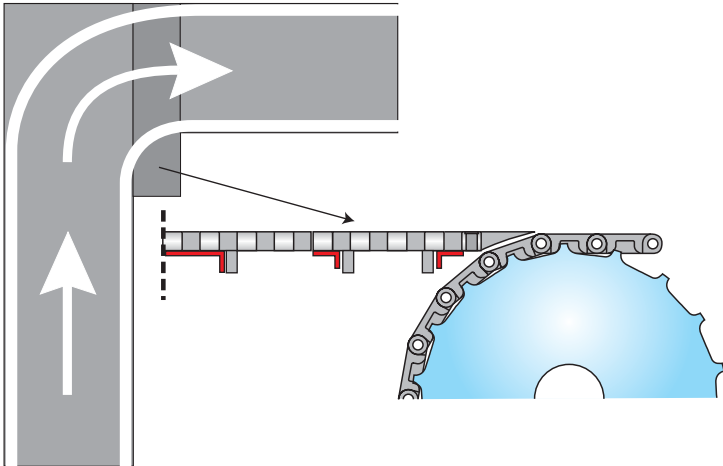

Active transfer wing with two positioners:

See below overview for the positioning of the active transfer wing relative to the infeed and outfeed conveyor:

This is a system of integrated, tapered flights at the edge of the belt which allows for smooth 90° transfers without dead plates resulting in a self clearing line.

The active transfer system is always equipped with the positioner which ensures an optimum tracking of the belt at the 90° transfer.

We recommend making the return shaft adjustable in X-and Y- direction within a range of some millimeters in order to obtain a perfect transfer.

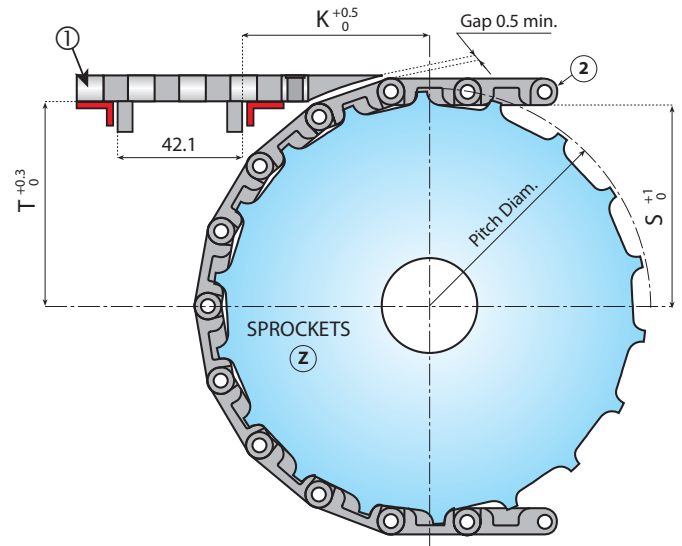

BELTS with transfer wing (Ref. n°1)	BELTS (Ref. n°2)	SPROCKETS Number of teeth Z.	DIMENSIONS		
			K (mm)	S (mm)	T (mm)
2120 FTTP2	2120 FT	16	55.2	28.2	28.2
		20	56.4	36.3	36.3
		24	57.5	44.3	44.3
		28	59.5	52.4	52.4
2250 FTTP2	2120 FT	16	55.5	28.2	28.2
		20	56.6	36.3	36.3
		24	57.6	44.3	44.3
		28	60.1	52.4	52.4
2250 FTTP2	2250 FT or 2250 FG	12	58.6	44.7	44.7
		16	60.7	60.7	60.7
		18	61.6	68.8	68.8
		20	62.4	76.8	76.8
2250 FTTP2	2190 FT or 2190 FG	17	69	46	46
		21	85.8	58.6	58.6
		24	97.1	67.1	67.1
		25	101.1	70.1	70.1
2251 FTTP2	2251 FT or 2252 FT	16	79.5	58.7	58.7
		18	80.2	66.7	66.7
		20	80.5	74.8	74.8
		21	81.4	78.9	78.9
2251 FTTP2L2	2251 FT or 2252 FT	16	104.9	58.7	58.7
		18	105.6	66.7	66.7
		20	105.9	74.8	74.8
		21	106.8	78.9	78.9

The same dimensions are applicable for belts series 2121 and 2252.

Going straight in a narrow space a **HEAD-TO-TAIL** transfer can be used:

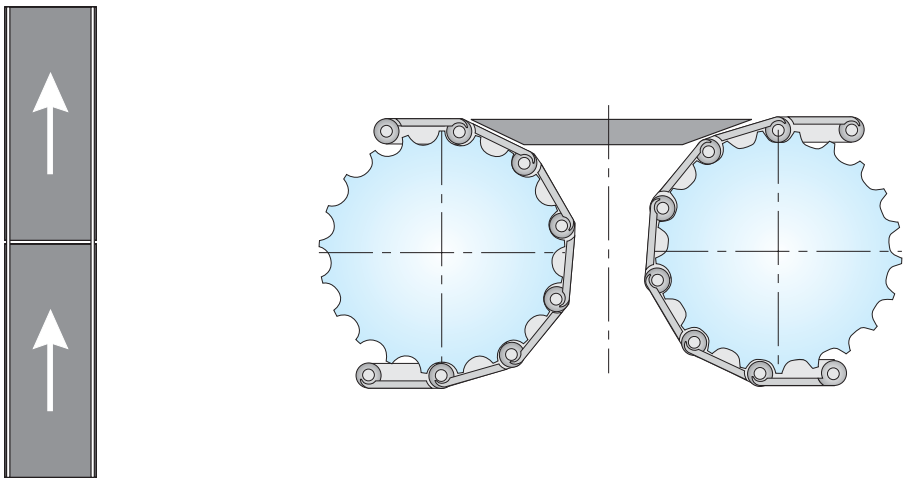

The gap between the sprocket and idler can be covered with a dead plate. Depending on the size of the product/pack and the length of the dead plate, it will require some other products/packs to push the first one across the dead plate.

To reduce to length of the dead plate, a smaller sprocket/idler can be chosen. However we do not recommend to work with very small sprockets/idlers because of increased cordal action and small number of teeth in operation.

An option to reduce the pressure necessary to get products/packs across the transfer is the use of roller transfers:

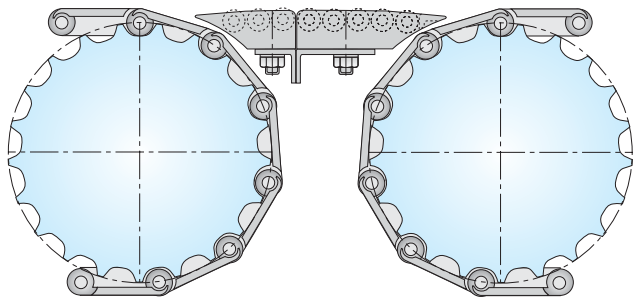

System Plast has 4 types of rollers available:

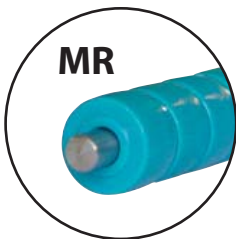

Plastic multi



Single plastic



Plastic with ball bearing

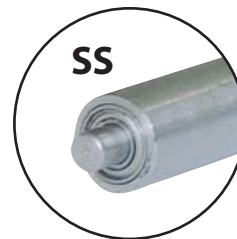

SS with ball bearing

The modules are designed in 3 sizes with 2, 3 or 5 rollers. For further details refer to the components catalogue. See next page for positioning dimensions.

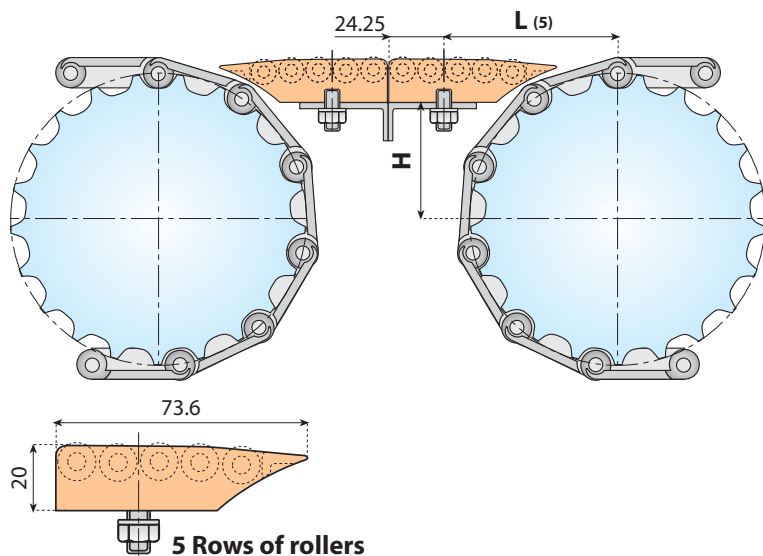
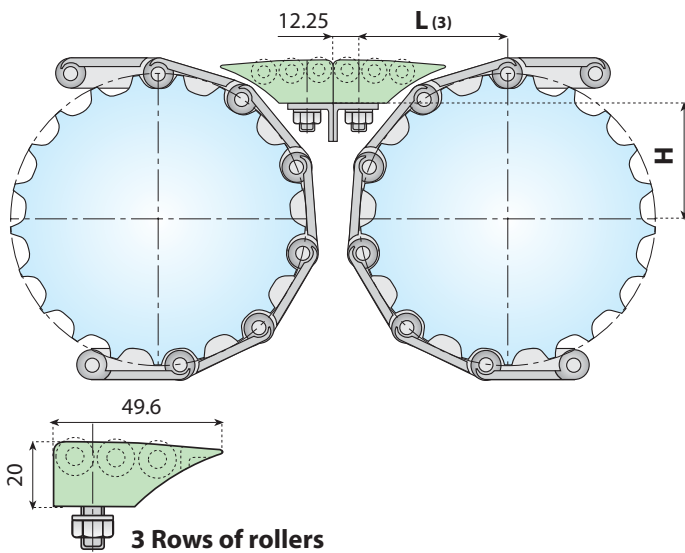
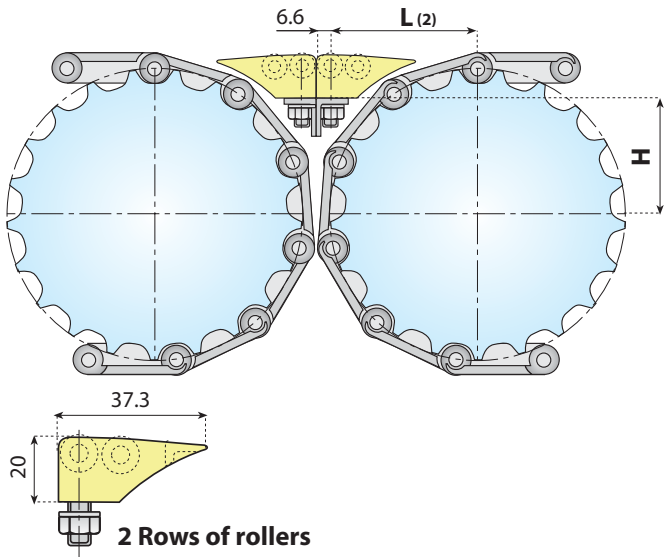

Combinations

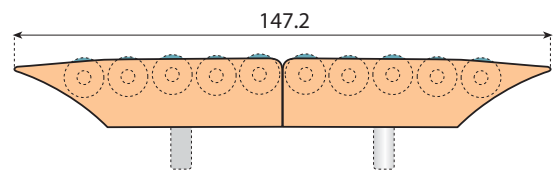
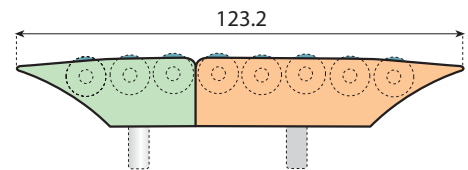
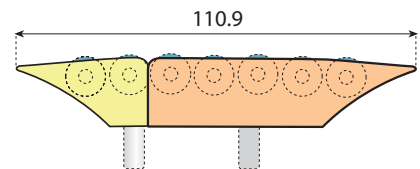
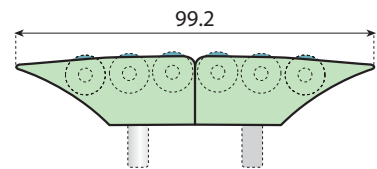
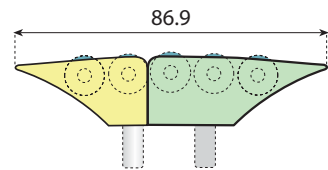
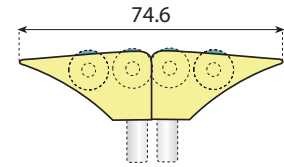

Head to tail transfer with two modules

CHAIN TYPES

	Sprockets Z=17		Sprockets Z=19		Sprockets Z=21		Sprockets Z=23		Sprockets Z=25		Sprockets Z=27		Sprockets Z=29			
	H	L(2) L(3) L(6)	H	L(2) L(3) L(6)	H	L(2) L(3) L(6)	H	L(2) L(3) L(6)	H	L(2) L(3) L(6)	H	L(2) L(3) L(6)	H	L(2) L(3) L(6)		
812, 815, 881, 8157, 8810, 800, 802, 805, 812L, 815L, 881 M, 881 MO, 881 TAB, 8810 TAB, 8857 M, 8857 TAB, L 881 MO	39,6	67,2 79,2 104,0 45,5 70,1 81,6 105,4 51,5	40,2	67,2 78,9 103,0 46,1 70,2 81,3 104,4 52,1	41,0	67,9 79,2 103,1 46,9 70,8 81,6 104,4 52,9	41,0	67,9 79,2 103,1 46,9 70,8 81,6 104,4 52,9	41,0	67,9 79,2 103,1 46,9 70,8 81,6 104,4 52,9	41,0	67,9 79,2 103,1 46,9 70,8 81,6 104,4 52,9	41,0	67,9 79,2 103,1 46,9 70,8 81,6 104,4 52,9	41,0	67,9 79,2 103,1 46,9 70,8 81,6 104,4 52,9
805 VG, 815 TAB VG, 815 VG, 881 TAB VG, 881 VG, 8157 VG, 8157 TAB VG, 8857 M VG, 815 VG MINI 831, 820, 820J	42,6	68,3 80,0 103,6 48,5 71,3 82,3 104,9 54,5	42,1	67,9 79,7 103,6 48,0 70,9 82,1 104,9 54,0	42,1	67,9 79,7 103,6 48,0 70,9 82,1 104,9 54,0	42,1	67,9 79,7 103,6 48,0 70,9 82,1 104,9 54,0	42,1	67,9 79,7 103,6 48,0 70,9 82,1 104,9 54,0	42,1	67,9 79,7 103,6 48,0 70,9 82,1 104,9 54,0	42,1	67,9 79,7 103,6 48,0 70,9 82,1 104,9 54,0	42,1	67,9 79,7 103,6 48,0 70,9 82,1 104,9 54,0
821	40,2	67,2 78,9 103,0 46,1 70,2 81,3 104,4 52,1	41,0	67,9 79,2 103,1 46,9 70,8 81,6 104,4 52,9	41,0	67,9 79,2 103,1 46,9 70,8 81,6 104,4 52,9	41,0	67,9 79,2 103,1 46,9 70,8 81,6 104,4 52,9	41,0	67,9 79,2 103,1 46,9 70,8 81,6 104,4 52,9	41,0	67,9 79,2 103,1 46,9 70,8 81,6 104,4 52,9	41,0	67,9 79,2 103,1 46,9 70,8 81,6 104,4 52,9	41,0	67,9 79,2 103,1 46,9 70,8 81,6 104,4 52,9
831 VG	44,0	68,9 79,9 103,7 49,9 71,3 82,4 105,0 55,9	44,0	68,9 79,9 103,7 49,9 71,3 82,4 105,0 55,9	44,0	68,9 79,9 103,7 49,9 71,3 82,4 105,0 55,9	44,0	68,9 79,9 103,7 49,9 71,3 82,4 105,0 55,9	44,0	68,9 79,9 103,7 49,9 71,3 82,4 105,0 55,9	44,0	68,9 79,9 103,7 49,9 71,3 82,4 105,0 55,9	44,0	68,9 79,9 103,7 49,9 71,3 82,4 105,0 55,9	44,0	68,9 79,9 103,7 49,9 71,3 82,4 105,0 55,9
LBP 831	54,7	L(3) 82,9 106,6 60,6 L(3) 85,6 108,1 111,1 78,6	54,7	L(3) 82,9 106,6 60,6 L(3) 85,6 108,1 111,1 78,6	54,7	L(3) 82,9 106,6 60,6 L(3) 85,6 108,1 111,1 78,6	54,7	L(3) 82,9 106,6 60,6 L(3) 85,6 108,1 111,1 78,6	54,7	L(3) 82,9 106,6 60,6 L(3) 85,6 108,1 111,1 78,6	54,7	L(3) 82,9 106,6 60,6 L(3) 85,6 108,1 111,1 78,6	54,7	L(3) 82,9 106,6 60,6 L(3) 85,6 108,1 111,1 78,6	54,7	L(3) 82,9 106,6 60,6 L(3) 85,6 108,1 111,1 78,6
LBP 821	55,5	L(3) 84,1 107,4 61,4 L(3) 86,8 108,9 67,4	55,5	L(3) 84,1 107,4 61,4 L(3) 86,8 108,9 67,4	55,5	L(3) 84,1 107,4 61,4 L(3) 86,8 108,9 67,4	55,5	L(3) 84,1 107,4 61,4 L(3) 86,8 108,9 67,4	55,5	L(3) 84,1 107,4 61,4 L(3) 86,8 108,9 67,4	55,5	L(3) 84,1 107,4 61,4 L(3) 86,8 108,9 67,4	55,5	L(3) 84,1 107,4 61,4 L(3) 86,8 108,9 67,4	55,5	L(3) 84,1 107,4 61,4 L(3) 86,8 108,9 67,4
SK 38	38,7	66,3 78,4 102,3 44,6 69,2 80,8 103,7 50,6	38,7	66,3 78,4 102,3 44,6 69,2 80,8 103,7 50,6	38,7	66,3 78,4 102,3 44,6 69,2 80,8 103,7 50,6	38,7	66,3 78,4 102,3 44,6 69,2 80,8 103,7 50,6	38,7	66,3 78,4 102,3 44,6 69,2 80,8 103,7 50,6	38,7	66,3 78,4 102,3 44,6 69,2 80,8 103,7 50,6	38,7	66,3 78,4 102,3 44,6 69,2 80,8 103,7 50,6	38,7	66,3 78,4 102,3 44,6 69,2 80,8 103,7 50,6

CHAIN TYPES

	Sprockets Z=9		Sprockets Z=10		Sprockets Z=11		Sprockets Z=12	
	H	L(2) L(3) L(6)	H	L(2) L(3) L(6)	H	L(2) L(3) L(6)	H	L(2) L(3) L(6)
828, 879, 880, 879 J, 880 J, 879 TAB, 880 TAB, 879 M, 880 M	43,0	68,6 79,6 103,7 49,0 71,7 81,8 105,1 55,0	43,0	68,6 79,6 103,7 49,0 71,7 81,8 105,1 55,0	43,0	68,6 79,6 103,7 49,0 71,7 81,8 105,1 55,0	43,0	68,6 79,6 103,7 49,0 71,7 81,8 105,1 55,0
878 TAB	43,4	68,7 79,8 103,4 49,4 L(3) 82,0 104,9 55,4	43,4	68,7 79,8 103,4 49,4 L(3) 82,0 104,9 55,4	43,4	68,7 79,8 103,4 49,4 L(3) 82,0 104,9 55,4	43,4	68,7 79,8 103,4 49,4 L(3) 82,0 104,9 55,4
879 TAB VG, 879 M VG	46,0	70,1 80,7 104,6 52,0 L(3) 83,2 105,9 58,0	46,0	70,1 80,7 104,6 52,0 L(3) 83,2 105,9 58,0	46,0	70,1 80,7 104,6 52,0 L(3) 83,2 105,9 58,0	46,0	70,1 80,7 104,6 52,0 L(3) 83,2 105,9 58,0
878 TAB VG	46,4	70,7 80,3 104,4 52,4 L(3) 82,9 105,6 58,4	46,4	70,7 80,3 104,4 52,4 L(3) 82,9 105,6 58,4	46,4	70,7 80,3 104,4 52,4 L(3) 82,9 105,6 58,4	46,4	70,7 80,3 104,4 52,4 L(3) 82,9 105,6 58,4
LBP 878 TAB, LBP 879 M	58,4	L(3) 85,1 107,3 64,4 L(3) 87,7 108,5 70,4	58,4	L(3) 85,1 107,3 64,4 L(3) 87,7 108,5 70,4	58,4	L(3) 85,1 107,3 64,4 L(3) 87,7 108,5 70,4	58,4	L(3) 85,1 107,3 64,4 L(3) 87,7 108,5 70,4
8257, 882 BEVEL, 882 TAB, 882 M	45,6	70,2 80,1 104,0 51,5 L(3) 82,6 105,4 57,6	45,6	70,2 80,1 104,0 51,5 L(3) 82,6 105,4 57,6	45,6	70,2 80,1 104,0 51,5 L(3) 82,6 105,4 57,6	45,6	70,2 80,1 104,0 51,5 L(3) 82,6 105,4 57,6
8257 VG, 882 TAB VG, 882 M VG	48,6	71,7 80,7 104,9 54,5 L(3) 83,4 106,3 60,6	48,6	71,7 80,7 104,9 54,5 L(3) 83,4 106,3 60,6	48,6	71,7 80,7 104,9 54,5 L(3) 83,4 106,3 60,6	48,6	71,7 80,7 104,9 54,5 L(3) 83,4 106,3 60,6
LBP 8257, LBP 882 TAB, LBP 882 M	60,1	L(3) 85,6 107,8 66,0 L(3) 87,1 108,8 72,1	60,1	L(3) 85,6 107,8 66,0 L(3) 87,1 108,8 72,1	60,1	L(3) 85,6 107,8 66,0 L(3) 87,1 108,8 72,1	60,1	L(3) 85,6 107,8 66,0 L(3) 87,1 108,8 72,1

CHAIN TYPES

	Sprockets Z=13		Sprockets Z=15		Sprockets Z=17		Sprockets Z=18		Sprockets Z=19		Sprockets Z=21		Sprockets Z=23		Sprockets Z=25	
	H	L(2) L(3) L(6)	H	L(2) L(3) L(6)	H	L(2) L(3) L(6)	H	L(2) L(3) L(6)	H	L(2) L(3) L(6)	H	L(2) L(3) L(6)	H	L(2) L(3) L(6)	H	L(2) L(3) L(6)
515	39,9	66,5 79,0 102,8 47,9 70,5 82,2 104,8 56,0	39,9	66,5 79,0 102,8 47,9 70,5 82,2 104,8 56,0	39,9	66,5 79,0 102,8 47,9 70,5 82,2 104,8 56,0	39,9	66,5 79,0 102,8 47,9 70,5 82,2 104,8 56,0	39,9	66,5 79,0 102,8 47,9 70,5 82,2 104,8 56,0	39,9	66,5 79,0 102,8 47,9 70,5 82,2 104,8 56,0	39,9	66,5 79,0 102,8 47,9 70,5 82,2 104,8 56,0	39,9	66,5 79,0 102,8 47,9 70,5 82,2 104,8 56,0

BELT TYPES

	Sprockets Z=14		Sprockets Z=16		Sprockets Z=20		Sprockets Z=24		Sprockets Z=28		Sprockets Z=36		Sprockets Z=38		Sprockets Z=40			
	H	L(2) L(3) L(6)	H	L(2) L(3) L(6)	H	L(2) L(3) L(6)	H	L(2) L(3) L(6)	H	L(2) L(3) L(6)	H	L(2) L(3) L(6)	H	L(2) L(3) L(6)	H	L(2) L(3) L(6)		
2120 K134, K200, 2120 FT, FG, 2120M, 2121 FT	13,4	59,1 71,0 94,9 17,4 60,7 72,3 95,9 25,5 63,9 75,0 98,0	13,4	59,1 71,0 94,9 17,4 60,7 72,3 95,9 25,5 63,9 75,0 98,0	13,4	59,1 71,0 94,9 17,4 60,7 72,3 95,9 25,5 63,9 75,0 98,0	13,4	59,1 71,0 94,9 17,4 60,7 72,3 95,9 25,5 63,9 75,0 98,0	13,4	59,1 71,0 94,9 17,4 60,7 72,3 95,9 25,5 63,9 75,0 98,0	13,4	59,1 71,0 94,9 17,4 60,7 72,3 95,9 25,5 63,9 75,0 98,0	13,4	59,1 71,0 94,9 17,4 60,7 72,3 95,9 25,5 63,9 75,0 98,0	13,4	59,1 71,0 94,9 17,4 60,7 72,3 95,9 25,5 63,9 75,0 98,0	13,4	59,1 71,0 94,9 17,4 60,7 72,3 95,9 25,5 63,9 75,0 98,0
GB 2120, VG 2120 K200, VG 2120 LBP 2120	14,9	59,5 71,5 95,5 18,9 61,1 72,8 96,5 27,0 64,4 75,5 98,6	14,9	59,5 71,5 95,5 18,9 61,1 72,8 96,5 27,0 64,4 75,5 98,6	14,9	59,5 71,5 95,5 18,9 61,1 72,8 96,5 27,0 64,4 75,5 98,6	14,9	59,5 71,5 95,5 18,9 61,1 72,8 96,5 27,0 64,4 75,5 98,6	14,9	59,5 71,5 95,5 18,9 61,1 72,8 96,5 27,0 64,4 75,5 98,6	14,9	59,5 71,5 95,5 18,9 61,1 72,8 96,5 27,0 64,4 75,5 98,6	14,9	59,5 71,5 95,5 18,9 61,1 72,8 96,5 27,0 64,4 75,5 98,6	14,9	59,5 71,5 95,5 18,9 61,1 72,8 96,5 27,0 64,4 75,5 98,6	14,9	59,5 71,5 95,5 18,9 61,1 72,8 96,5 27,0 64,4 75,5 98,6
	15,4	59,9 71,8 95,8 19,4 61,6 73,1 96,8 27,5 64,8 75,8 98,8	15,4	59,9 71,8 95,8 19,4 61,6 73,1 96,8 27,5 64,8 75,8 98,8	15,4	59,9 71,8 95,8 19,4 61,6 73,1 96,8 27,5 64,8 75,8 98,8	15,4	59,9 71,8 95,8 19,4 61,6 73,1 96,8 27,5 64,8 75,8 98,8	15,4	59,9 71,8 95,8 19,4 61,6 73,1 96,8 27,5 64,8 75,8 98,8	15,4	59,9 71,8 95,8 19,4 61,6 73,1 96,8 27,5 64,8 75,8 98,8	15,4	59,9 71,8 95,8 19,4 61,6 73,1 96,8 27,5 64,8 75,8 98,8	15,4	59,9 71,8 95,8 19,4 61,6 73,1 96,8 27,5 64,8 75,8 98,8	15,4	59,9 71,8 95,8 19,4 61,6 73,1 96,8 27,5 64,8 75,8 98,8

BELT TYPES

	Sprockets Z=17		Sprockets Z=21		Sprockets Z=24		Sprockets Z=25	
	H	L(2) L(3) L(6)	H	L(2) L(3) L(6)	H	L(2) L(3) L(6)	H	L(2) L(3) L(6)
2190 FT, 2190 FG	35,2	65,5 77,5 101,5 47,9 71,2 81,4 104,3 56,3	35,2	65,5 77,5 101,5 47,9 71,2 81,4 104,3 56,3	35,2	65,5 77,5 101,5 47,9 71,2 81,4 104,3 56,3	35,2	65,5 77,5 101,5 47,9 71,2 81,4 104,3 56,3

BELT TYPES

	Sprockets Z=12		Sprockets Z=13		Sprockets Z=14		Sprockets Z=15		Sprockets Z=16		Sprockets Z=18		Sprockets Z=20		Sprockets Z=21			
	H	L(2) L(3) L(6)	H	L(2) L(3) L(6)	H	L(2) L(3) L(6)	H	L(2) L(3) L(6)	H	L(2) L(3) L(6)	H	L(2) L(3) L(6)	H	L(2) L(3) L(6)	H	L(2) L(3) L(6)		
2250 FT, 2250 FG VG 2250	31,0	64,7 76,5 100,2 34,8 66,5 77,9 101,2 38,8 68,2 79,3	31,0	64,7 76,5 100,2 34,8 66,5 77,9 101,2 38,8 68,2 79,3	31,0	64,7 76,5 100,2 34,8 66,5 77,9 101,2 38,8 68,2 79,3	31,0	64,7 76,5 100,2 34,8 66,5 77,9 101,2 38,8 68,2 79,3	31,0	64,7 76,5 100,2 34,8 66,5 77,9 101,2 38,8 68,2 79,3	31,0	64,7 76,5 100,2 34,8 66,5 77,9 101,2 38,8 68,2 79,3	31,0	64,7 76,5 100,2 34,8 66,5 77,9 101,2 38,8 68,2 79,3	31,0	64,7 76,5 100,2 34,8 66,5 77,9 101,2 38,8 68,2 79,3	31,0	64,7 76,5 100,2 34,8 66,5 77,9 101,2 38,8 68,2 79,3
2251 FT, 2252 FT, 2252 PT VG 2251	37,5	66,0 78,3 102,0 41,3 67,9 79,8 103,0 45,3 69,9 81,3	37,5	66,0 78,3 102,0 41,3 67,9 79,8 103,0 45,3 69,9 81,3	37,5	66,0 78,3 102,0 41,3 67,9 79,8 103,0 45,3 69,9 81,3	37,5	66,0 78,3 102,0 41,3 67,9 79,8 103,0 45,3 69,9 81,3	37,5	66,0 78,3 102,0 41,3 67,9 79,8 103,0 45,3 69,9 81,3	37,5	66,0 78,3 102,0 41,3 67,9 79,8 103,0 45,3 69,9 81,3	37,5	66,0 78,3 102,0 41,3 67,9 79,8 103,0 45,3 69,9 81,3	37,5	66,0 78,3 102,0 41,3 67,9 79,8 103,0 45,3 69,9 81,3	37,5	66,0 78,3 102,0 41,3 67,9 79,8 103,0 45,3 69,9 81,3
LBP 2251	49,5	L(3) 81,2 105,2 53,3 L(3) 83,0 106,2 57,3	49,5	L(3) 81,2 105,2 53,3 L(3) 83,0 106,2 57,3	49,5	L(3) 81,2 105,2 53,3 L(3) 83,0 106,2 57,3	49,5	L(3) 81,2 105,2 53,3 L(3) 83,0 106,2 57,3	49,5	L(3) 81,2 105,2 53,3 L(3) 83,0 106,2 57,3	49,5	L(3) 81,2 105,2 53,3 L(3) 83,0 106,2 57,3	49,5	L(3) 81,2 105,2 53,3 L(3) 83,0 106,2 57,3	49,5	L(3) 81,2 105,2 53,3 L(3) 83,0 106,2 57,3		

BELT TYPES

||
||
||

Dyna Plate:

There's also a special series "Dyna Plate" with slightly different dimensions and a centre module:

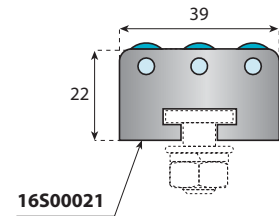
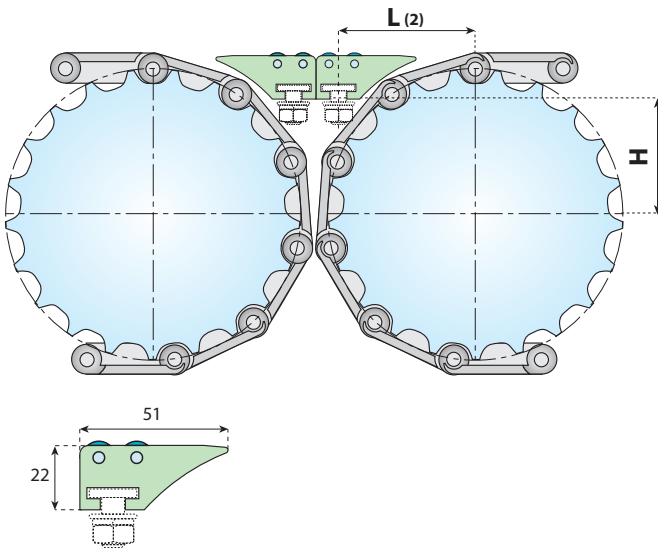

By the use of the centre module the transfer can be elongated in steps of 39 mm to reach the desired transfer length.

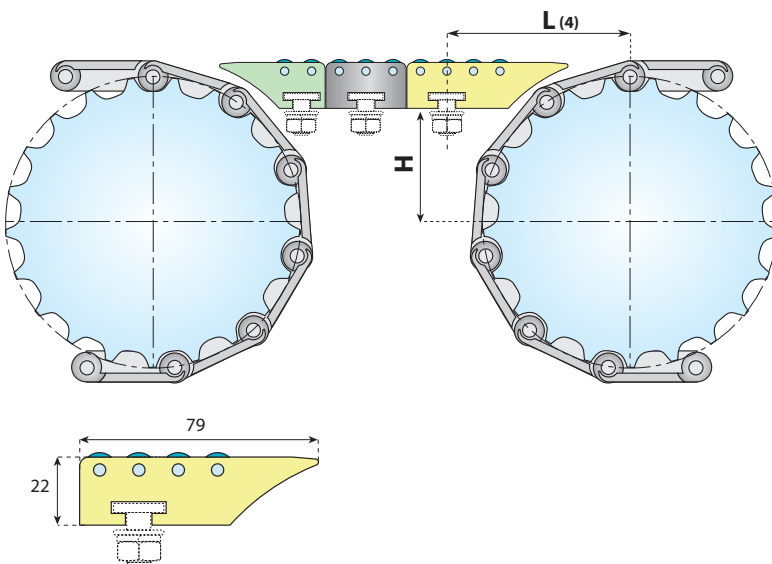

Combinations

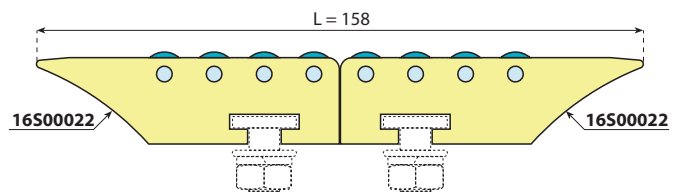
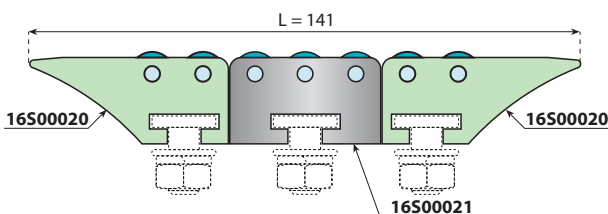
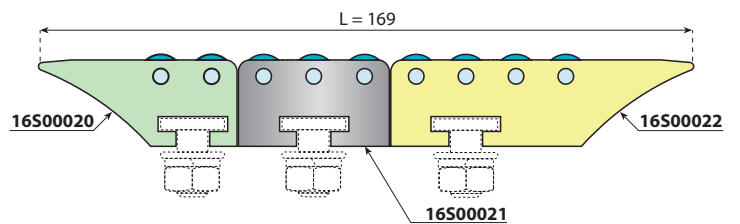
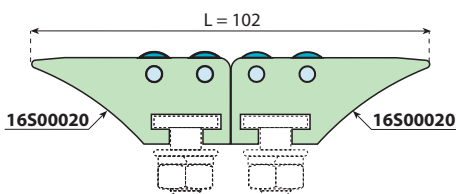

CHAIN TYPES	Sprockets Z=17		Sprockets Z=19		Sprockets Z=21		Sprockets Z=23		Sprockets Z=25		Sprockets Z=27		Sprockets Z=29								
	H	L(4)	H	L(4)	H	L(4)	H	L(4)	H	L(4)	H	L(4)	H	L(4)							
812, 815, 881, 8157, 8810, 800, 802, 805, 812L, 815L, 881 M, 881 MO, 881 TAB, 8810 TAB, 8857 M, 8857 TAB, L 881 MO	37,1	80,9	109,4	43,0	83,8	110,8	49,0	86,7	112,2	55,0	89,5	113,6	61,0	92,4	115,0	66,9	95,3	116,4	72,9	98,1	117,7
805 VG, 815 TAB VG, 815 VG, 881 TAB VG, 881 VG, 8157 TAB VG, 8157 TAB VG, 8857 M VG, 815 VG MINI	40,1	82,0	109,0	46,0	85,0	110,3	52,0	87,9	111,7	58,0	90,8	113,0	64,0	93,7	114,3	69,9	96,6	115,6	75,9	101,1	117,0
831, 820, 820J, 821	39,6	81,6	109,0	45,5	84,6	110,3	51,5	87,6	111,5	57,5	90,6	112,7	63,5	93,6	113,9	69,4	96,6	115,1	75,4	101,1	116,3
831 VG	37,7	80,9	108,4	43,6	83,9	109,8	49,6	86,8	111,2	55,6	89,7	112,5	61,6	92,7	113,9	67,5	95,6	115,3	73,5	98,6	116,6
LBP 831	38,5	81,6	108,5	44,4	84,5	109,8	50,4	87,3	111,1	56,4	90,2	112,4	62,4	93,0	113,8	68,3	95,9	115,1	74,3	100,1	116,4
LBP 821	41,5	82,6	109,1	47,4	85,4	110,4	53,4	88,3	111,8	59,4	91,2	113,1	65,4	94,1	114,5	71,3	96,9	115,8	77,3	103,1	117,2
SK 38	52,2	88,3	112,0	58,1	91,0	113,5	64,1	93,6	115,0	70,1	96,3	116,5	76,1	104,1	118,1	82,0	104,1	119,6	88,0	121,1	121,1
	53,0	88,8	112,8	58,9	91,6	114,3	64,9	94,5	115,7	70,9	97,3	117,2	76,9	104,1	118,7	82,8	104,1	120,1	88,8	121,6	121,6
	36,2	80,0	107,7	42,1	82,9	109,1	48,1	85,9	110,4	54,1	88,8	111,7	60,1	91,8	113,1	66,0	94,7	114,4	72,0	97,7	115,7

CHAIN TYPES	Sprockets Z=9		Sprockets Z=10		Sprockets Z=11		Sprockets Z=12					
	H	L(4)	H	L(4)	H	L(4)	H	L(4)				
828, 879, 880, 879 J, 880 J, 879 TAB, 880 TAB, 879 M, 880 M, 878 TAB	40,5	82,3	109,1	46,5	85,4	110,5	52,5	88,6	111,8	58,5	91,7	113,1
879 TAB VG, 879 M VG, 878 TAB VG	40,9	82,4	108,8	46,9	85,4	110,3	52,9	88,5	111,9	58,9	91,5	113,4
LBP 878 TAB, LBP 879 M	43,5	83,8	110,0	49,5	86,8	111,3	55,5	89,9	112,7	61,5	92,9	114,1
8257, 882 BEVEL, 882 TAB, 882 M	43,9	84,4	109,8	49,9	87,4	111,0	55,9	90,5	112,2	61,9	93,6	113,4
8257 VG, 882 TAB VG, 882 M VG	55,9	90,3	112,7	61,9	93,0	113,9	67,9	95,8	115,1	73,9	101,4	116,2
LBP 8257, LBP 882 TAB, LBP 882 M	43,1	83,9	109,4	49,0	86,8	110,8	55,1	89,7	112,1	61,0	92,6	113,4
	46,1	85,4	110,3	52,0	88,3	111,7	58,1	91,1	113,1	64,0	94,0	114,5
	57,6	90,5	113,2	63,5	93,3	114,2	69,6	96,1	115,3	75,5	101,4	116,4

CHAIN TYPES	Sprockets Z=13		Sprockets Z=15		Sprockets Z=17		Sprockets Z=18		Sprockets Z=19		Sprockets Z=21		Sprockets Z=23		Sprockets Z=25								
	H	L(4)	H	L(4)	H	L(4)	H	L(4)	H	L(4)	H	L(4)	H	L(4)	H	L(4)							
515	37,4	80,2	108,2	45,4	84,2	110,2	53,5	88,2	112,1	57,5	90,2	113,1	61,5	92,2	114,1	69,6	96,2	116,1	77,6	104,1	118,0	85,7	120,0

BELT TYPES	Sprockets Z=14		Sprockets Z=16		Sprockets Z=20		Sprockets Z=24		Sprockets Z=28		Sprockets Z=36		Sprockets Z=38		Sprockets Z=40									
	H	L(4)	H	L(4)	H	L(4)	H	L(4)	H	L(4)	H	L(4)	H	L(4)	H	L(4)								
2120 K134, K200, 2120 FT, FG, 2120M, 2121 FT	10,9	72,8	100,3	14,9	74,4	101,3	23,0	77,6	103,4	31,0	80,8	105,5	39,1	84,1	107,6	55,3	90,5	111,8	59,3	92,1	112,9	63,3	93,7	113,9
GB 2120, VG 2120 K200, VG 2120, LBP 2120	12,4	73,2	100,9	16,4	74,8	101,9	24,5	78,1	104,0	32,5	81,3	106,1	40,6	84,5	108,2	56,8	91,0	112,4	60,8	92,6	113,5	64,8	94,3	114,5
	12,9	73,6	101,2	16,9	75,3	102,2	25,0	78,5	104,2	33,0	81,7	106,3	41,1	84,9	108,3	57,3	91,4	112,4	61,3	93,0	113,4	65,3	94,6	114,4

BELT TYPES	Sprockets Z=17		Sprockets Z=21		Sprockets Z=24		Sprockets Z=25					
	H	L(4)	H	L(4)	H	L(4)	H	L(4)				
2190 FT, 2190 FG	32,7	79,2	106,9	45,4	84,9	109,7	53,8	89,3	111,9	56,9	90,7	112,6

BELT TYPES	Sprockets Z=12		Sprockets Z=13		Sprockets Z=14		Sprockets Z=15		Sprockets Z=16		Sprockets Z=18		Sprockets Z=20		Sprockets Z=21									
	H	L(4)	H	L(4)	H	L(4)	H	L(4)	H	L(4)	H	L(4)	H	L(4)	H	L(4)								
2250 FT, 2250 FG	26,5	78,4	105,6	32,3	80,2	106,6	36,3	81,9	107,6	40,3	83,7	108,5	44,3	85,4	109,5	52,3	89,0	111,4	60,4	92,5	113,3	64,4	94,3	114,3
VG 2250	31,0	79,0	106,6	34,8	80,8	107,5	38,8	82,6	108,5	42,8	84,4	109,4	46,8	86,2	110,4	54,8	89,8	112,3	62,9	93,5	114,2	66,9	95,3	115,1
2251 FT, 2252 FT, 2252 PT	32,5	79,0	107,0	36,3	80,8	107,9	40,3	82,7	108,8	44,3	84,6	109,7	48,3	86,5	110,6	56,3	90,2	112,4	64,4	94,0	114,2	68,4	95,9	115,1
VG 2251	35,0	79,7	107,4	38,8	81,6	108,4	42,8	83,6	109,4	46,8	85,5	110,3	50,8	87,5	111,3	58,8	91,4	113,2	66,9	95,3	115,1	70,9	97,3	116,1
LBP 2251	47,0	85,6	110,6	50,8	87,5	111,6	54,8	89,3	112,6	58,8	91,1	113,6	62,8	93,0	114,6	70,8	96,6	116,6	78,9	104,1	118,7	82,9	119,7	

BELT TYPES	Sprockets Z=10		Sprockets Z=13		Sprockets Z=15		Sprockets Z=16					
	H	L(4)	H	L(4)	H	L(4)	H	L(4)				
2351, 2451, 2551, 2651	33,3	79,0	107,2	48,3	86,7	111,1	57,9	91,9	113,7	64,7	94,5	115,0

CHAIN - BELT TYPES	Sprockets Z=16		Sprockets Z=18		Sprockets Z=19				
	H	L(4)	H	L(4)	H	L(4)			
2250 M, 2250 TAB, 2260 M, 2251 M, 2251 TAB	55,5	89,9	113,2	63,4	93,8	114,7	68,2	95,7	115,5
	59,9	92,1	113,5	67,8	95,9	115,3	72,6	97,8	116,2

Note: where there is no value in the table, but L(4), this means that the theoretical length would be more than the length of the module. In that case we recommend to use the next larger size L(4).

Nose bar transfer:

Although roller transfers reduce the pressure required, another option is a solution with only a very small gap. This can be done with a nose bar transfer

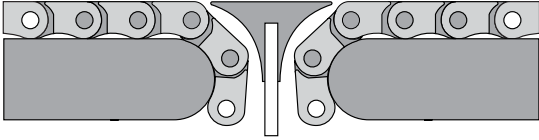

The 2120 series belt with 1/2" pitch and concave bottom is very well suited for nose bar transfers. The small pitch and the concave bottom reduce the polygon effect to an absolute minimum.

Either a static nose bar or a roller can be used.

The diameter should be 19-20 mm to fit the concave bottom of the modules.

Application example:



Recommended drive Construction in nose bar situation:

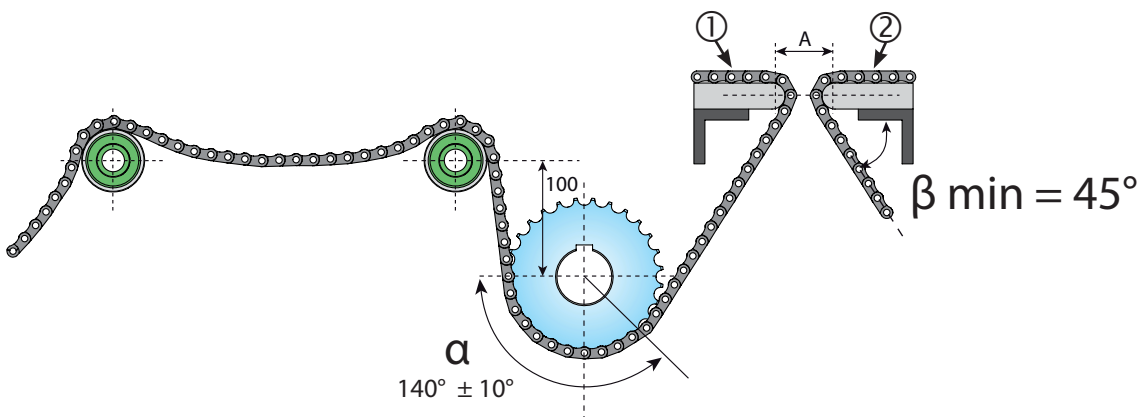

Dimension A for different 2120 belt types:

Type ①	Thickness	Type ②	Thickness	A
FT / FG	8.7	FT / FG	8.7	40
FT / FG	8.7	VG	10.7	42
FT / FG	8.7	LBP	21.5	53
VG	10.7	VG	10.7	44
VG	10.7	LBP	21.5	55
LBP	21.5	LBP	21.5	65

Wear strips

Construction:

There are different ways of supporting a chain or belt with wear strips:

- parallel support → most common; multiple strands chain/belt;
- full support → in case of heavy load and/or high impact;
- chevron/herringbone → wider belts in abrasive conditions.

Parallel:

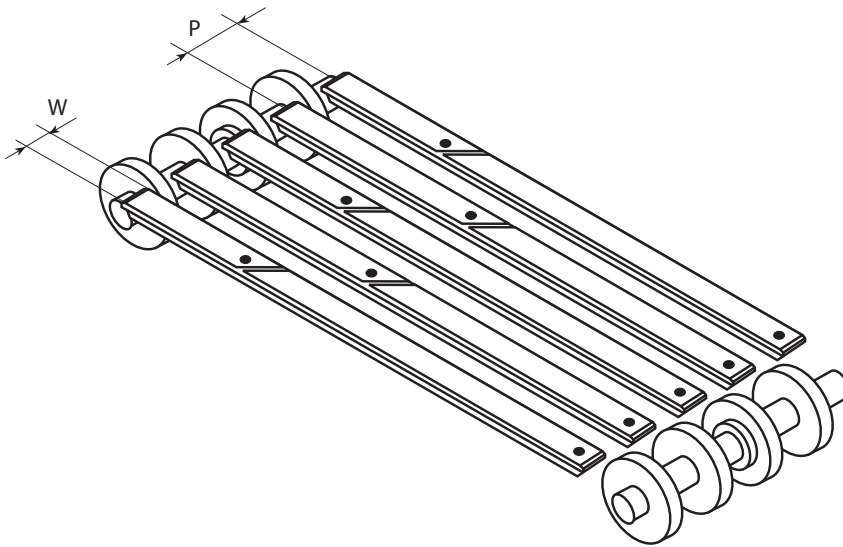

Recommended dimensions:

W= width of the wear strip ≥ 40 mm

P= pitch of the wear strips: with K325 or K330 wide chains mostly 85 mm. Larger with wider chains (max 170 mm).

Or 3"- 6" for imperial belt sizes.

For chains 7,5" and wider we recommend to install 2 wear strips on each side of the hinge. 1 close to the hinge and 1 at the edge of the plate.

Make sure the wear strip is chamfered at the entry side and that there's enough space between the lengths of wear strip to absorb thermal expansion:

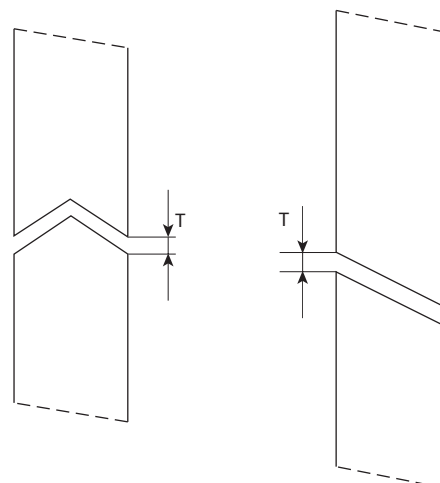
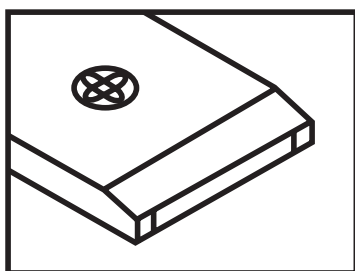

$T = \pm 10$ mm. Check thermal expansion rates. See [page 29](#)

CONVEYOR CONSTRUCTION

For belts with positioners, a parallel wear strip system is required.

Wear strip shoes are recommended for a smooth transfer onto the wear strip and reduction of noise:

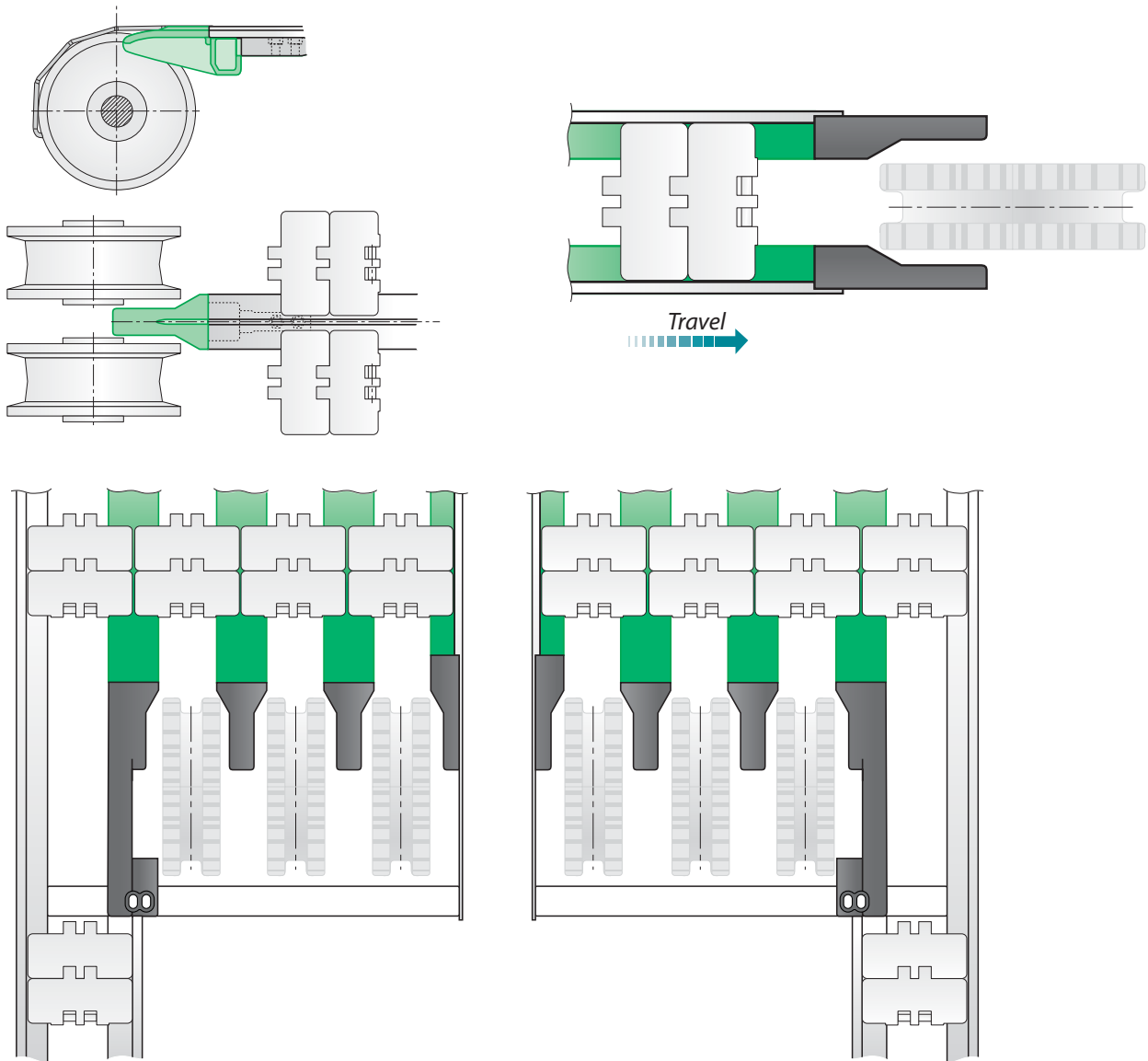

Further examples:

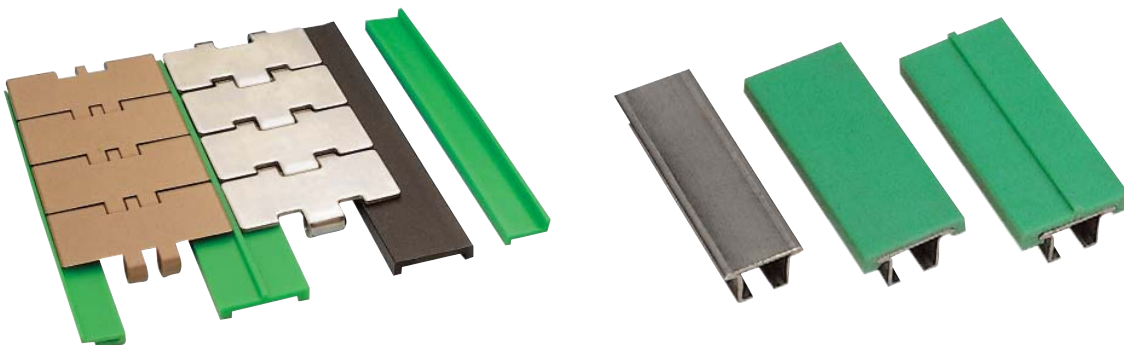

Full support:

In case of heavy loads or high impact, it's advisable to support the belt completely. Bear in mind that a full support can also easily collect dust and dirt. Make sure abrasives can leave the system. For reasons of accessibility we recommend to support the return way always with rollers.

Chevron/Herringbone:

The advantage of this principle is an even wear over the width of the belt. Therefore we recommend this system in abrasive conditions.

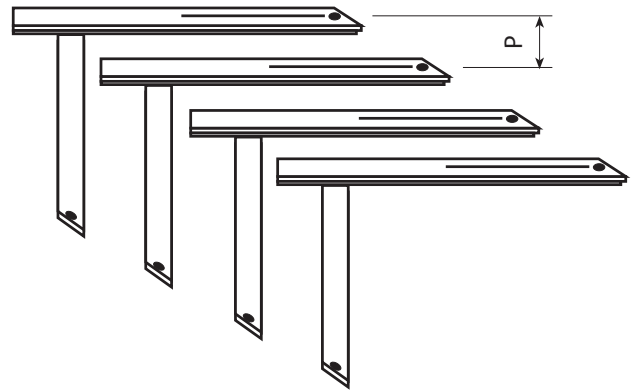

Pitch of wear strips: 100-300 mm.

Transfers between commonly used chain types – belts:

When a transfer has to be made from 1 chain/belt type to another, a difference in thickness may have to be absorbed by the wear strips underneath.

Example: Stainless steel chain 815 to 2250 and 2260M belt:

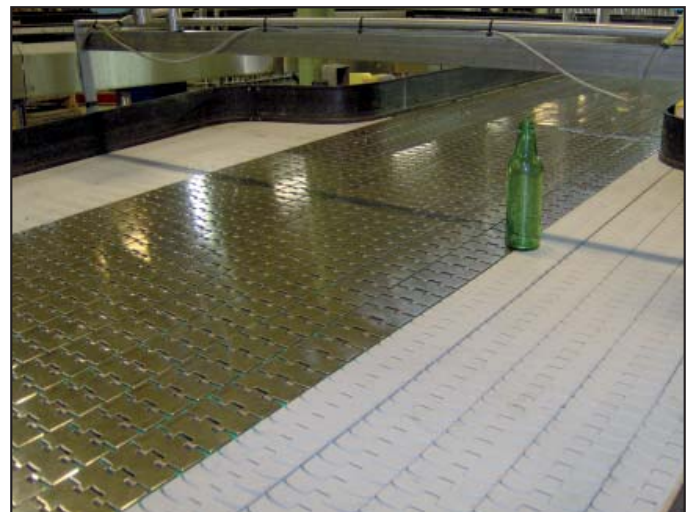

CONVEYOR CONSTRUCTION

The steel chain has a thickness of 3,1mm and the 2250 belt of 8,7mm. That means that the wear strip should absorb 5,6 mm of difference. See below table in red.

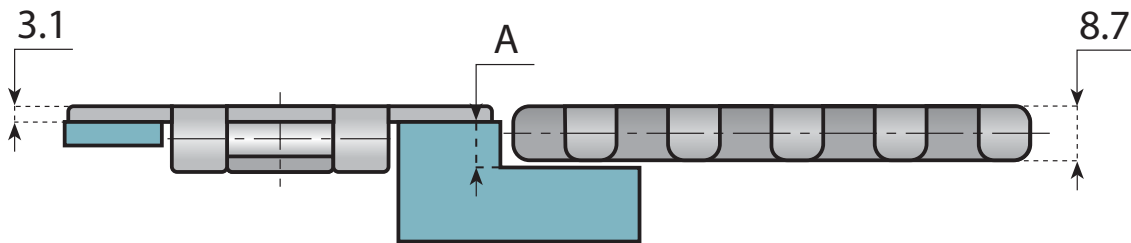

See table for other combinations:

Chain type	Thickness	Chain type	Thickness	Chain type	Thickness	Belt type	Thickness	Belt type	Thickness
812	3.1	820 (J)	4	831	4.8	2120FT	8.7	2251FT	12.7
815		828		821		2120FG		2252PT	
800/802/805		831		8257		2120M		2252FT	
8157		880 (J)		879 (J)		2121FT		2251M	
515		880TAB		879TAB		2190FT		2251TAB	
881		880M		879M		2190FG		2351	
8810		863		878TAB		2250FT		2451	
881TAB		1863		882BEVEL		2250FG		2551	
8810TAB		1873		882TAB		2250M		2651	
881M(O)/L				882M		2250TAB			
8857M						2260M			
8857TAB									
1874									
<p>Differences:</p> <p>all dimensions: [mm]</p> <p>0.9 ←</p> <p>1.7 ←</p> <p>5.6 ←</p> <p>9.6 ←</p> <p>0.8 ←</p> <p>4.7 ←</p> <p>8.7 ←</p> <p>3.9 ←</p> <p>7.9 ←</p> <p>4.0 ←</p>									

Selection of wear strip material:

Wear strip material	Steel chains	Plastic chains & belts	
	lubricated	dry	lubricated
UHMWPE	recommended	satisfactory for: <60 m/min	recommended
NOLU-S	possible	recommended	possible
Polyamide	not recommended	possible	possible
Stainless steel	not recommended	recommended	recommended
Carbon steel	not applicable	possible	not applicable

Temperature limits of wear strip materials must be considered.

UHMWPE

- to be used in non-abrasive conditions

NOLU-S

- UHMWPE with built in dry lubricant
- offers even lower coefficient of friction and less noise emission than standard UHMWPE
- basic material properties are similar to UHMWPE

Polyamide

- to be used in slightly abrasive conditions
- absorption of humidity to be considered

Stainless steel

- recommended for abrasive conditions
- hardness of 25-30 HRC is recommended
- roughness of max. 1.6µm is recommended

Carbon steel

- recommended for abrasive conditions
- hardness above 45 HRC is recommended
- roughness of max. 1.6µm is recommended

Calculation

Required data for chain/belt calculation:

Chain/belt and material specification		
Chain/belt type		
Chain/belt width	[mm or inch]	
Curve material		
Material straight upper part		
Material straight return part		
Product material		

Product details and conveyor specification		
Products/hour		
Product weight	[g]	
Diameter product	[mm]	
Product arrangement		
Product pitch		
Chain speed	[m/min]	
Lubrication		
Number of tracks		
Sprocket size	[teeth]	
Start up frequency		

Conveyor layout from idler to drive						
Section type	Length	Angle	Radius	Accumulation ¹	Occupation ²	Temperature
	[mm]	[%]	[mm]	[%]	[%]	[°C]
1						
2						
3						
4						
5						
6						
7						
8						
9						
10						

¹ Time percentage

² Part of the conveyor in accumulation

Required operation data

Please add a sketch of the conveyor layout.

Please describe operation conditions (e.g. abrasive conditions, chemicals environmental conditions, special operation requirements) in detail.

Please describe product features in detail, add drawings/sketches.

Replacement of chain/belts

Which chain was used before?

Did it work satisfactory or did problems occur?



Calculation program

Crate conveying

Commonly there are two ways of conveying crates.

With a single strand stainless steel 7½" chain. This chain will have to be lubricated.

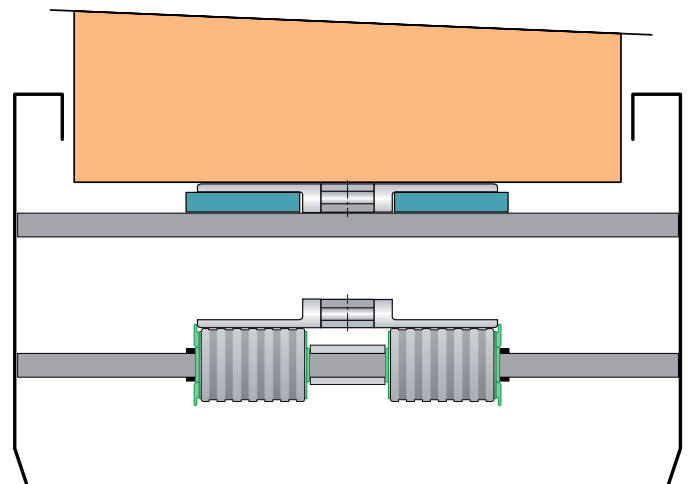

Principle sketch of a possible construction.

Especially when running dry two strands of the plastic CC 600 or CC1400/1431 chains can be used.

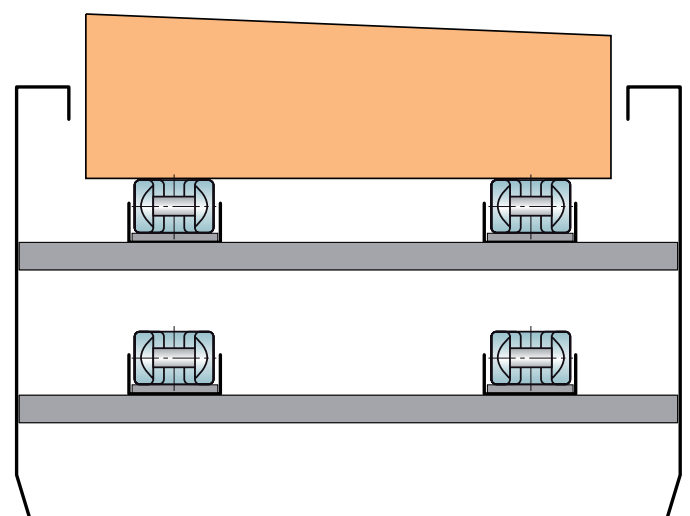
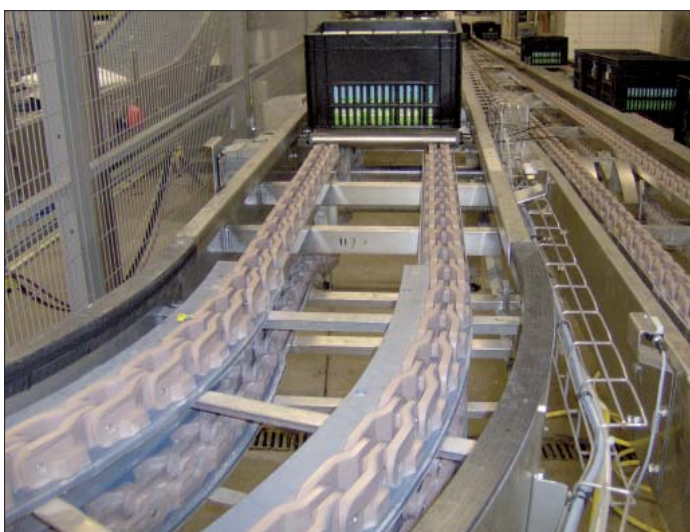

Principle sketch of a possible construction.

The CC chains tend to be supported and guided in a stainless steel track.

It is recommended to use UHMWPE wears strips underneath the chain in the stainless steel tracks.

APPLICATIONS

Curves:

CC chains are available with or without TAB. The chains can be guided in the curve in different ways:

Full curve with TAB's:

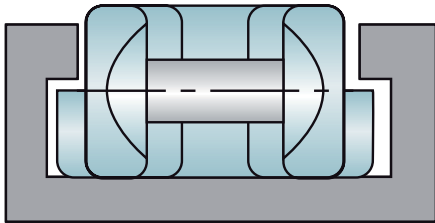

Open curve with TAB's:

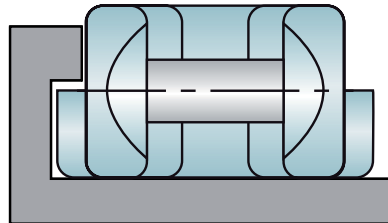

Separate guiding strips without TAB's:

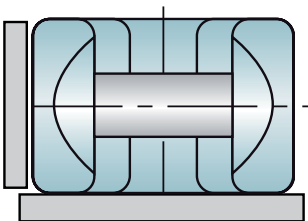

Open curve without TAB's:

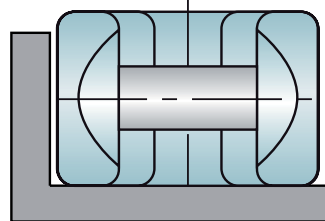

The curve construction should enable easy removal of debris. Also for cleaning purposes an open design is recommended to be able to lift the chain from the curve.

Transfers:

Depending on the application a dead plate can be used to make the transfer from one conveyor to the other:

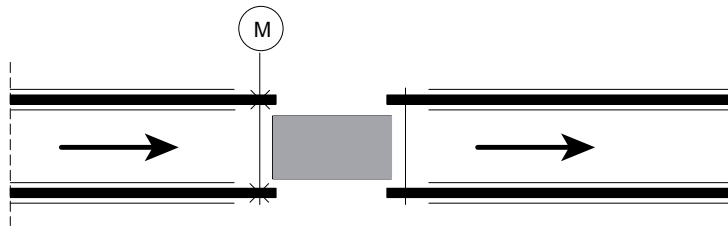

But due to the relative large pitch of the CC chains, the transfer of crates goes smoother with a dynamic transfer:

Slave drive:

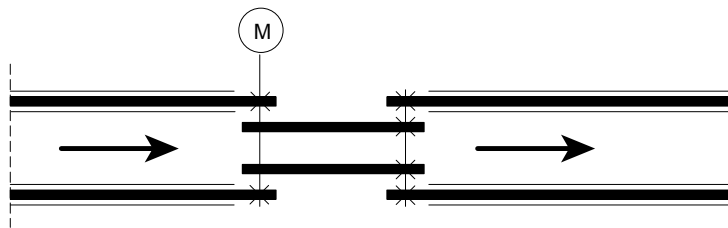

Staggered conveyors:

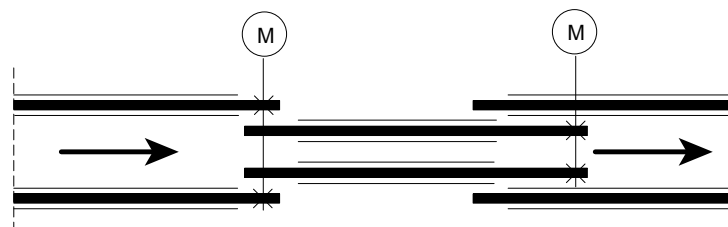

Gripper chains

- Chain tracks must be adjusted parallel. The tolerance for the parallel adjustment of the tracks is $< 2\text{mm}$. Incorrect adjustment can lead to overloading and a high wear of gripper-flights as well as of the basic roller chain.

- Gripper ribs must be oriented backwards relative to the running direction of the chain, as shown in the picture.

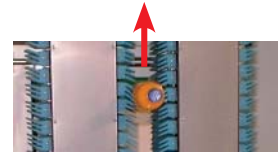

- The control system of the conveyor must assure that no backline pressure is created in order to avoid damage at gripper chains.

- The clearance between the chain tracks must be adjustable. Gripping forces must be adjusted according to the product.

General rule: as tight as necessary, as loose as possible.

The product must be removable by hand.

- A tensioning system is necessary. Tension should just take away the play out of the chain.

- Touching products must be avoided – particularly in curving sections. The gap between the products must be big enough.

- Lubrication helps to extend the service life of the chains as well as of the chain guides.

- EXTRA style curves with the stainless steel strip will significantly elongate the service life of the curves.

- Both chain strands must run at the same speed. Any speed differential causes damage at the chain and possibly also at the product. One central drive is recommended.

Selection of gripper version:

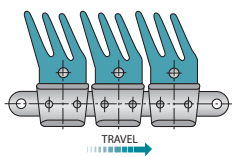

GS1: soft containers, e.g. empty PET bottles, empty cans, non pressurized containers.

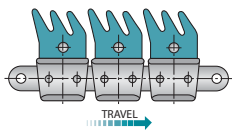

GS2: solid containers, e.g. glass bottles, pressurized containers.

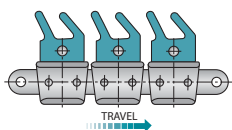

GS3: containers with non-cylindrical shape.



GS4: small containers.

Static electricity

Anti Static (AS) chain and belt material has the following properties: Surface resistivity: $10^5 \Omega/\text{sq}$
(According to IEC60093 test method) Volume resistivity: $10^3 \Omega\text{m}$

In order to avoid sparks:

- It must be assured on site that the electric charge is dissipated to the ground.
- Wear strips must be conductive and grounded.
- Sprockets and idler wheels must be conductive and grounded.

For further information regarding use of our AS chains in hazardous areas please contact our Technical Support.

Noise reduction

- Use plastic chains/belts instead of steel chains.
- When designing a layout use multiple strand or wider belt running at a lower speed rather than single strand or narrow belt running at higher speed.
- Avoid chain/belt colliding with conveyor parts.
- Reduce speed differentials and thus product impact.
- Use chains/belts with a small pitch (e.g. 2120/2121 belt series).
- Use sprockets with a big number of teeth.
- Adjust sprockets/idlers according to our recommendation in the catalogue (dimension "S"). (See image n°1)
- Use return guide shoes in carry as well as in return part. (See image n°2)
- Use sound-absorbing rubber coated return rollers or serpentine system for full chain/belt support. (See image n°3)
- Use materials with optimized sliding properties (e.g. Nolu-S wear strips, product guides and curves).
- Use our STM transfer instead of dead plate transfers. (See image n°4)
- Use curves instead of dead plate transfers.
- Apply lubrication.

Image n°1

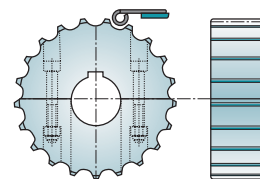

Image n°2



Image n°3



Image n°4

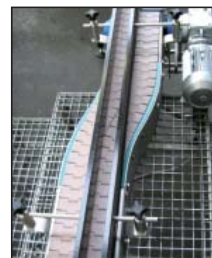

Inclined and declined conveyors

Maximum angles to avoid product sliding down on the chain

Chain type	Lubricated	Dry
Stainless steel	4°	*8°
Plastic chains/belt	2.5°	4.5°
Rubber top chains steel/plastic	12/15°	15/20°

*Dry run with steel chains is generally not recommendable

Pollution on the chain as well as on the product surface influences the maximum angles negatively.

Drive construction:

Location of drive in order to run chains safely and without roof-building effect.

Declines:

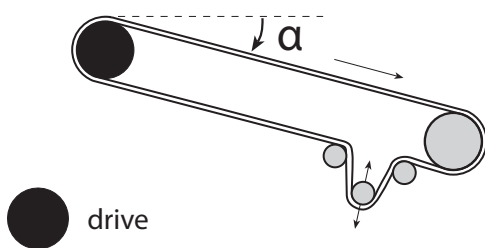

$\tan(\alpha) >$ friction coefficient between chain and wearstrips
Soft start/stop is recommended.

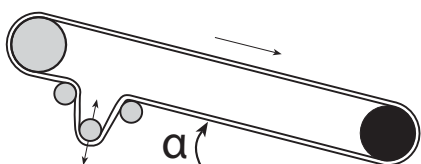

$\tan(\alpha) <$ friction coefficient between chain and wearstrips
Soft start/stop is recommended.

Dynamic tensioner is in both cases recommended.

Inclines:

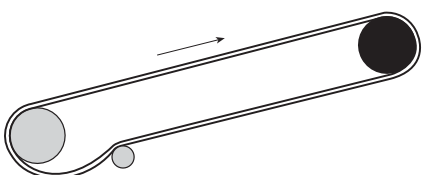

Drive is normally located at the upper end.
Soft start/stop is recommended.



Integrated transfer

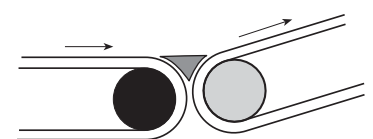

separate transfer
e.g. with dead plate

Hold down guide, resp. TAB chain

Curve construction in combination with inclines/declines:

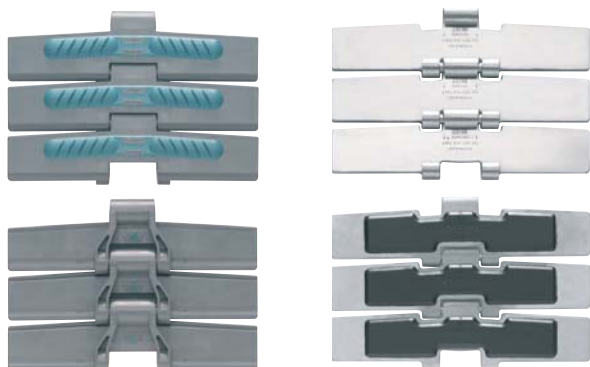

Sideflexing chains for Magnetic System can be used in inclined/declined conveyors only under the following restrictions:

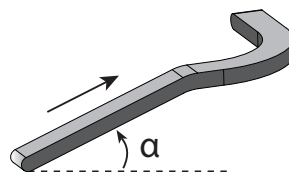

Incline is possible before a curve

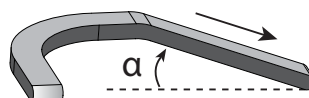

Decline is possible after a curve

Otherwise the chain could be lifted out.

Accumulation

Accumulation of products results in increased load on the chain as well as in increased wear on chain/belt and product.

LBP (Low Back Pressure) chains/belts are recommended to reduce these effects.

With low noise accumulation rollers the friction and other negative resulting effects are reduced to a minimum.

For the **return part construction** flat surfaces or guide shoes are recommended.

Frequent and thorough cleaning of LBP chains/belts is recommended to make sure that the accumulation rollers run free. Otherwise the advantages of this construction get lost.



Example



Pressureless combiners

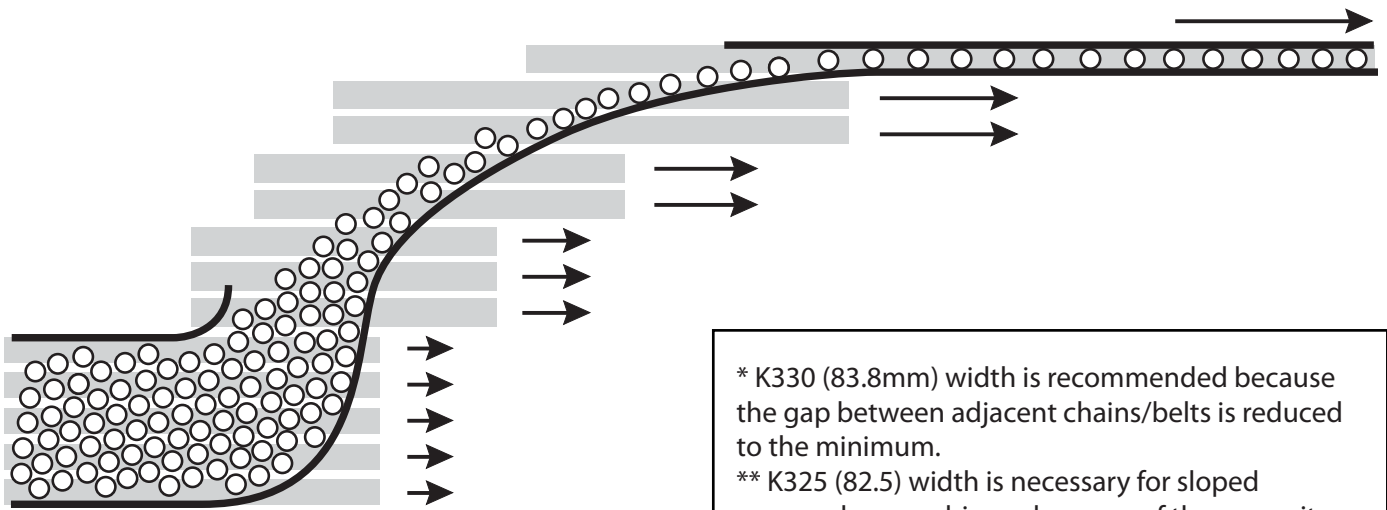

* K330 (83.8mm) width is recommended because the gap between adjacent chains/belts is reduced to the minimum.
 ** K325 (82.5) width is necessary for sloped pressureless combiners, because of the necessity to mouth separating discs in the return way.

Suitable chains/belts:

Usually pressureless combiners have a track pitch of 85 mm.

Type		Characteristics	Suitable for
Stainless steel chains	* K330 ** K325 SPEED-LINE	Extremely close tolerances in terms of: flatness, surface finish, no sharp edges.	Glass PET (returnable)
Plastic chains	LF, XPG, NG * K330; ** K325	Low friction.	PET Cans
Belts	2250 FT, FTP2 2250 FG, FGP2 2250 M FT 2250 M FG * K330	With Positioner. Closed or open surface. Low friction. Excellent stiffness. 1" pitch.	FG series: Cans FT series: Glass, PET
	2251 FTP2 * K330 2252 FTP2 ** K325	With Positioner. Closed surface. Heavy duty design. Low friction. Excellent stiffness. 1" pitch.	Glass PET Cans
	2190 FTP2 ** K325 2190 FGP2 ** K325	With Positioner. Closed or open surface. Low friction. Excellent stiffness. ¾" pitch.	FG series: Cans FT series: Glass, PET
	2120 FTP2 * K330 2121 FTP2 ** K325	With Positioner. Closed surface. Low friction. Excellent stiffness. 1/2" pitch. Small transfer	Cans PET Glass for unstable products

Dry lubrication

There are several developments in the market concerning lubrication.

There's a tendency to try to go away from wet lubrication to either semi-wet lubrication, dry lubrication or completely dry (no lube at all).

In some industries and situations wet lubrication is still the best and easiest to handle lubrication system.

But in a growing number of cases semi-wet lubrication or dry lubrication can be used. Also System Plast continues to develop designs and materials that can handle applications completely without lubrication. Talk to us about your application!

Semi- wet lubrication is fluid like water but should not be mixed with water before applying. This system tends to be used more on stainless steel chains than plastic.

Dry lubrication is most often a mineral oil with a built in lubricant like Teflon or silicon. There are different principles on the market. Check with your supplier for further details.

The amount of dry lubricant that's applied is close to nothing. It forms a thin layer on the chain/belt to get the requested sliding properties. Advantages are obvious. Small amount of lubricant required; no water; no waste water; simple installation; no drip trays, etc.

Dry lubricant is presently used mainly with cartons, bricks, PET bottles and cans at normal line capacities.

There are several suppliers on the market using different products and applying it in different ways:

Brushes

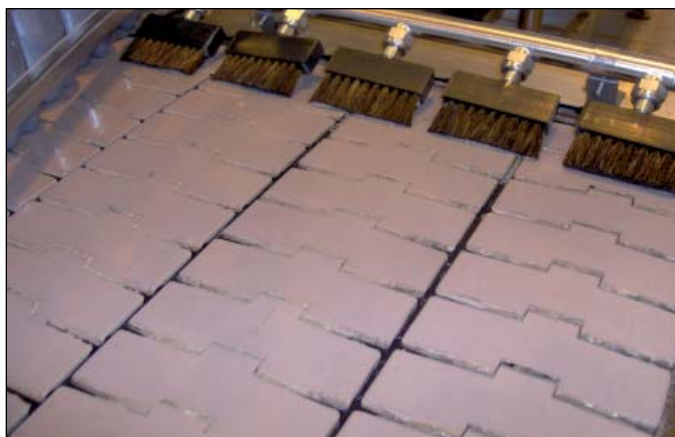

Shoes



Nozzles:



Although the different suppliers suggest different ways of bringing the lubricant from buffer to the chains/belts, the basic principle is the same:

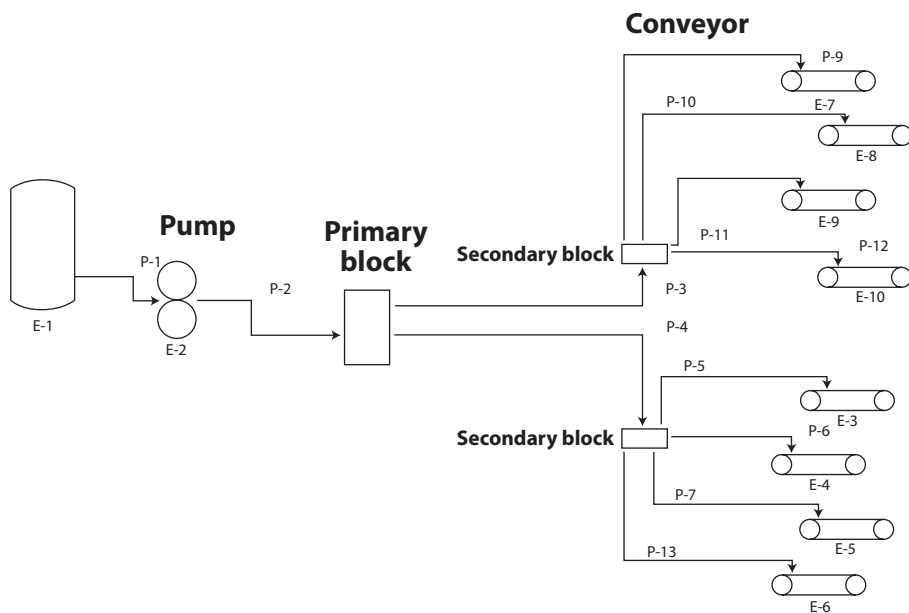

Question is how to evenly apply about 5 ml lubricant per hour on the chain/ belt.

Dry lubrication can bring advantages like:

- Reduction of cost for waste water.
- Reduction of cost for dosing hardware. No drip trays necessary.
- Safety → no slippery floors due to foam of wet lubrication.
- Hygiene → less or no water; no slime build up.
- No corrosion attack on equipment.
- No false rejects due to foam on bottles at inspectors.
- No water/foam on labels.
- No moisture on packaging material.

APPLICATIONS

But **important is to use it correctly**. Dry lubrication requires a different 'mind-set' compared to wet lubrication:

- Wet lubrication requires a minimum, (..as long as there's minimum 20cm foam on the floor...)
- Dry lubrication requires a maximum (smallest possible; when you see it, it's already too much)

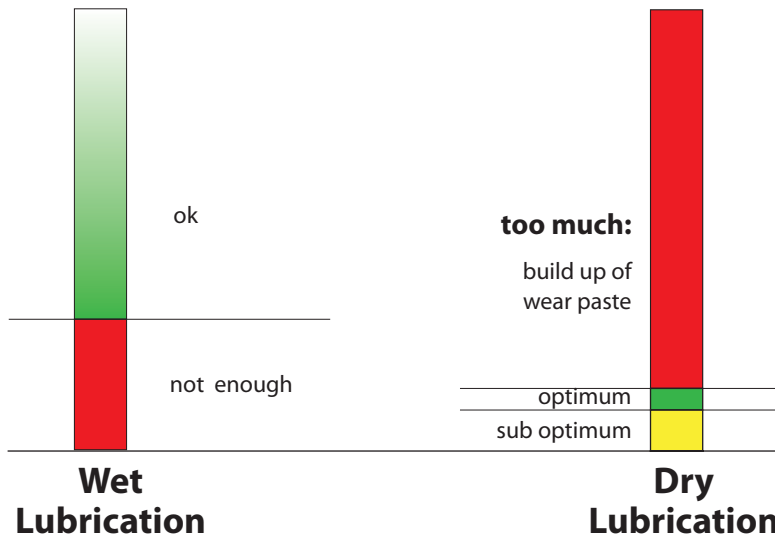

If you don't stay within the green zone, after some time the chain may look like this:

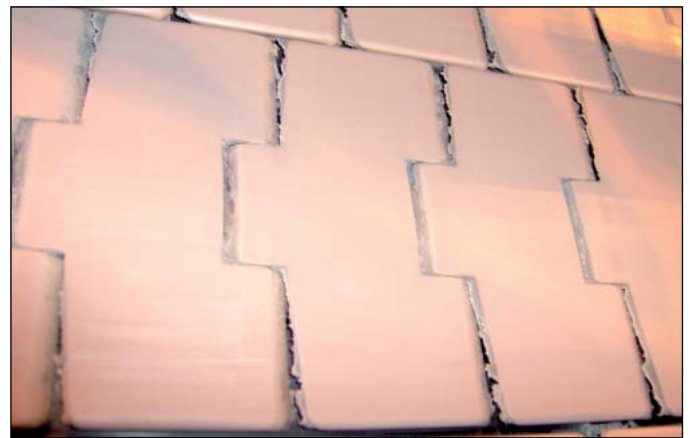

That's why it's very important to take a couple of things into consideration:

Dry lubrication requires maintenance to avoid built-up of pollution, regardless whether it's a system with brushes:

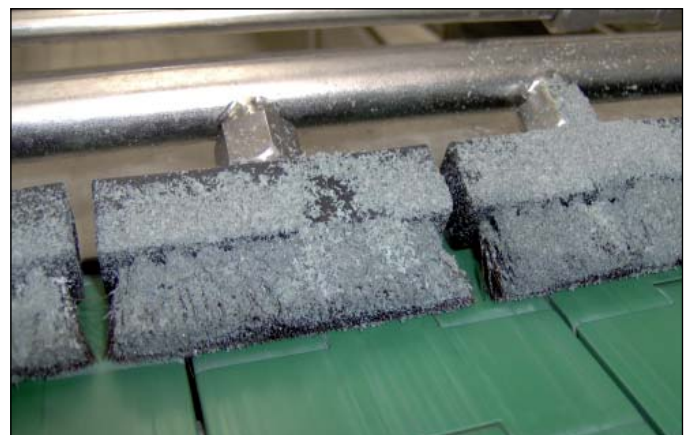

...with shoes:



...or with nozzles:

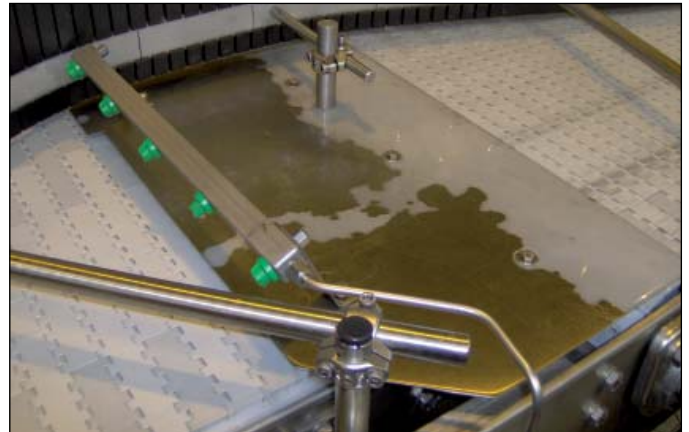

The responsibilities for maintenance and the lubrication have to be clear and preferably with the same person that's technically responsible for the line.

Dry lubrication has a high potential. But to get the full benefit it's good to take also following effects into consideration:

	Cleaning	Product quality	Process	Mechanical	Factor H
Dry running					
Dry lubrication	More dedicated ↑ End user	Higher influence ↑ End user / OEM	Engineering mind set ↑ End user / OEM	Details are important ↑ OEM	Human factor ↑ End - user
Semi wet lubrication					
Wet lubrication					

See further explanation on the next pages.

Cleaning:

The cleaning regime needs to be re-evaluated when going away from wet lubrication because:

- Wet lubricant has also cleaning effect
- More dedicated cleaning is required f.e. where product loss occurred

Product quality:

The type and quality of the material has an influence on the behaviour on the conveyors like:

- Quality of PET
 - Raw material
 - Colorants
 - Blockers
 - Other additives
 - Design/ settings of machine
- Quality of Cans
 - Steel/ aluminium
 - Painted or varnished
 - Design
 - Material thickness
- Quality of Glass
 - Raw material; origin
 - New or returnable
 - Design
 - Surface finish of bottle

Process:

When designing a layout please bear in mind that the line is going to run without wet lubrication. Think about:

- Wider conveyors → slower speed
- Longer inliners/outliners
- Shorter buffer sections → Back Line Pressure
- Optimised line controls
- Larger radius curves

Mechanical:

Some small mechanical issues on conveyors that seem not to create problems need to be addressed when going away from wet lubrication. Make sure that the chains/belts are running completely free (without obstruction).

Some points of attention:

- Nolu-S wear strips and curves with built-in lubricant can replace the wet lubrication to a certain extent.
- Perfect alignment of different sections.
- Smooth transfers of wear strips.
- Stable and straight side guides at right position.
- Positioning of sprockets and idlers.
- Smooth transfer straight into curve.

Factor H:

The most important factor is the Human Factor: the people that are dealing with the line.

- How do the local people deal with the line?
- Who's responsible?
- How are the contracts made?
- 'Mind set' change when reducing lubrication!
- Never mix products! → f.e. teflon spray in combination with dry lubricant creates high friction

So, is Dry Lubricant a good idea?

- Yes, in a good number of cases it brings interesting advantages.
- But be aware of the down side to get the full benefit!

Completely dry may be better?

- In certain areas of the bottling line and certain products: yes
 - Depalletiser + outfeed conveyors
 - Labelling, coding and packaging areas
 - Cans and PET and even glass
 - Beware of abrasives & chemicals

System Plast continues to develop products and materials that are able to run well even **completely dry** in certain circumstances like:

- Nolu-S wear strip / curve / side guide material
- NG chain material
- 828 chain design
- 'extra' curve design with metal strip
- Maintenance free bearings and TPM/SMED products that require less attention.

In any case, since every situation is different, please contact our specialists.

Powerflex

Calculation information:

Powerflex modular side flexing belts are used design to convey packs and boxes. In most applications the load on the belt can be relatively high because:

- The products are heavy
- There is usually no lubrication
- Many times the belts has to make a 180° turn
- In the curve there is only a limited part of the belt (only the outer part) that is pulling.

Therefore it is very important that every application of a side flexing belt is calculated prior to fixing the final layout of the line. Our Technical Support department will be glad to assist you with the calculations.



Conveyor layout:

When you are implementing a conveyor with a side flexing belt in a layout, there are several things to consider. If possible we recommend positioning the curve close to the idler end rather than close to the drive side. This will reduce the forces on the belt in the curve. Once the belt is on the straight section between the last curve and the drive end, there usually is no problem to add some length to the conveyor. On the straight section the strength of the belt is quite high.

We have some recommendations regarding the minimum straight section before, after and in between curves. See following illustration.

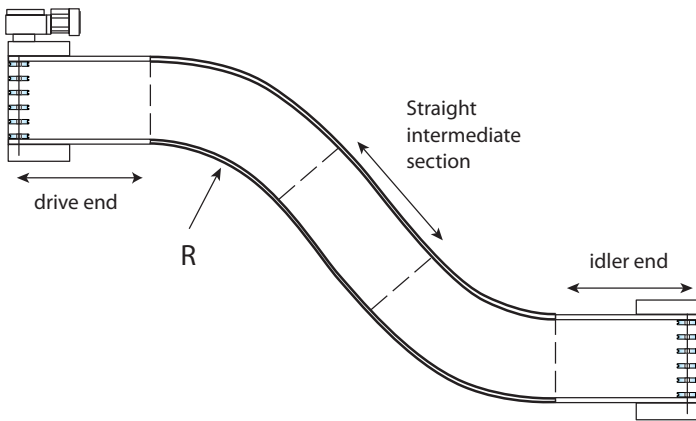

Length of straight section 'drive end':
1 x belt width with a minimum of 800mm

Length of straight section 'idler end':
1 x belt width with a minimum of 500mm

Length of straight intermediate section for
S-curves with 2351 type belt:
Minimum 1.5 x belt width

Curve radius R:
See tables below

Minimum inside curve radius R				
Width	2351	2451	2551	2651
255	408	-	-	-
340	545	545	340	-
425	680	680	425	425
510	840	840	510	510
595	980	980	595	595
680	1150	1150	680	680
765	1300	1300	850	850
850	1450	1450	1050	1050

Construction details:

Straight tracks:

The design is similar to commonly applied standard constructions.

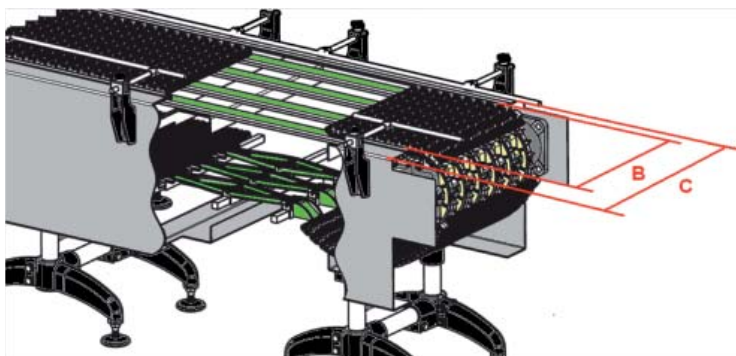

Example:
end drive and serpentine return

B = belt width, example 425 mm

C = conveyor width, example $425 + 10(\text{inside}) + 10(\text{outside}) = 445$ mm net (side frame thickness not considered)

Note that a catenary sag is required directly after the drive in the return part.

SIDEFLEXING BELTS

Wear strips:

On the straight track any existing wear strip from our extensive range can be used (see catalogue 'Conveyor Components').

Examples:

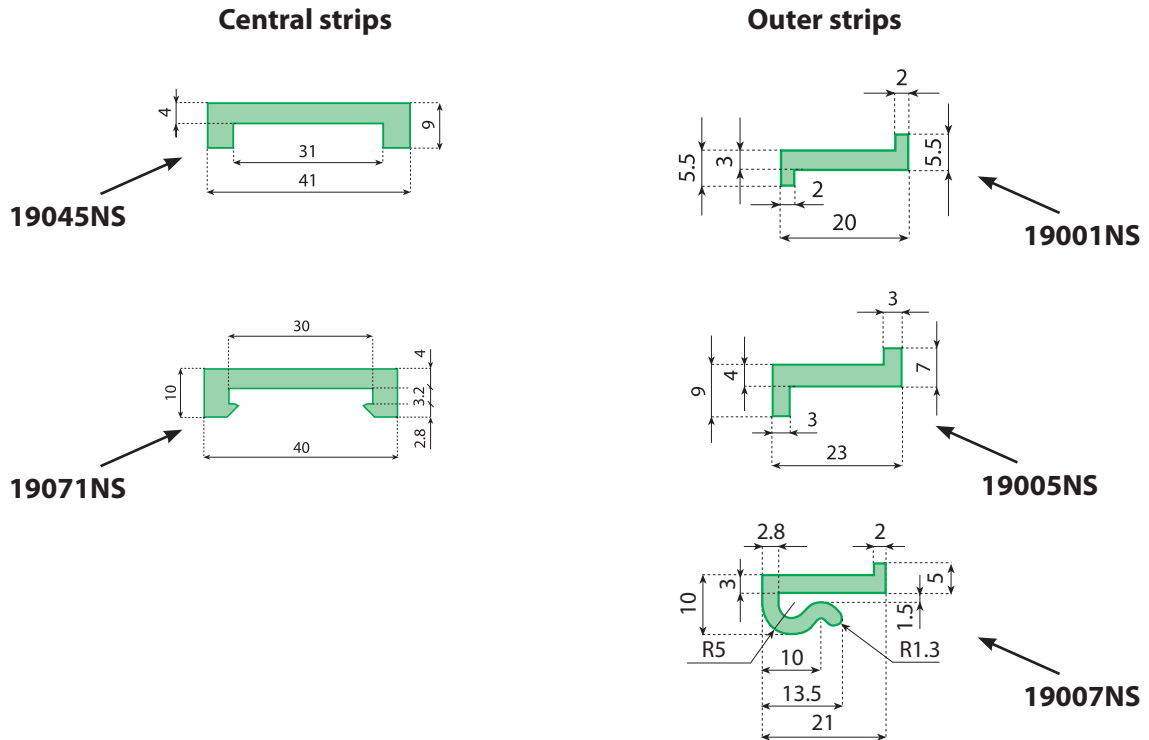

For good sliding properties Nolu-S material is recommended. This reduces the chain pull and extends the service life.

A possible cross section design of straight carry and return part is this:

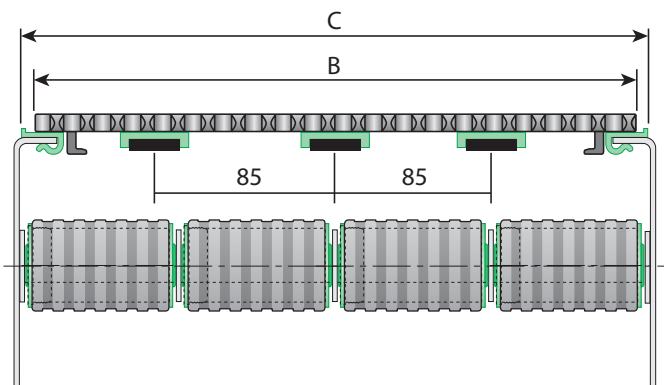

For location of TABs and other dimensions refer to catalogue.

Return rollers with rubber coating offer low noise and extended service life.

Since the belts are made with a modular width system of 85mm, it is recommended to use this system for the wear strip arrangement as well.

Curve tracks:

There are three options:

1) Dedicated guiding profile for standard or Heavy duty belt types.
This is fixed to the metal frame construction.
These Nolu-SR profiles are available in 3 meter lengths.

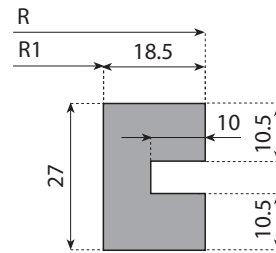

2) Solid machined curve.
This can only be offered on request and according to customer's drawing.
Principle is similar to existing TAB curves for TAB chains.
See further notes regarding the curve return part.

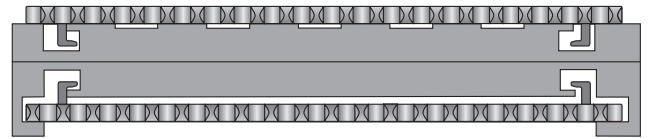

3) Side guiding profiles for 2351 series belt without TAB.
When a belt without TABs is used, it needs to be guided at both sides.

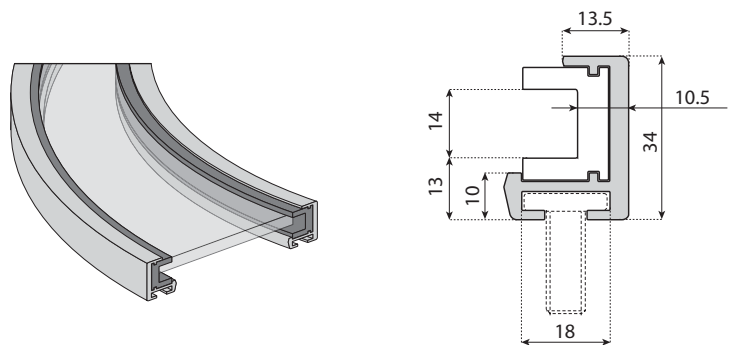

Material:

We recommend Nolu-SR material for its high wear resistance and at the same time excellent sliding properties.

Other options are:

- Extra strip: A stainless steel wearstrip fitted into a plastic curve
Proven excellent performance in dry applications and dirty environments.
- Standard UHMW-PE material: For lubricated applications with low wear expected.

SIDEFLEXING BELTS

Taking the belt out of the curve:

The conveyor construction must offer enough space to lift the TABs out of the track.

A clearance of at least 10 mm for standard belts and 6 mm for Heavy Duty belts is recommended to move the belt towards the outside of the curve.

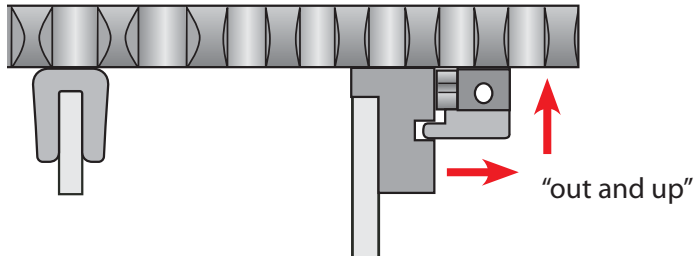

Infeed/Outfeed:

It is strongly recommended to extend the curve tracks into the straight sections in order to run the belt smoothly into and out of the curve.

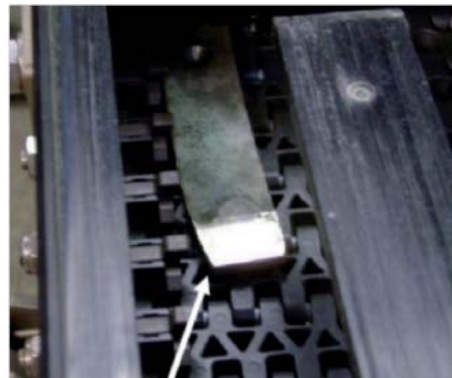
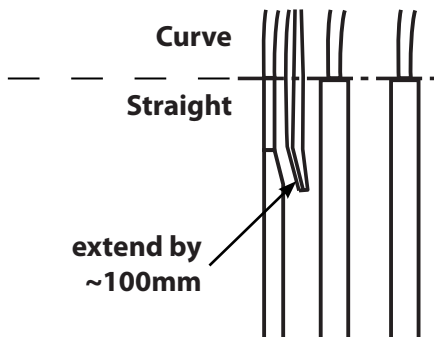

An infeed chamfer also of the outer plastic curve or wearstrip material is recommended for smooth running. Make sure that there is a proper chamfer both horizontal as well as vertical.



Cut like this

Curve return part:

2351 series with two TABs:

For belt widths up to 425 mm a full curve like this is possible.

Serpentine wearstrips are required for belts wider than 425mm.

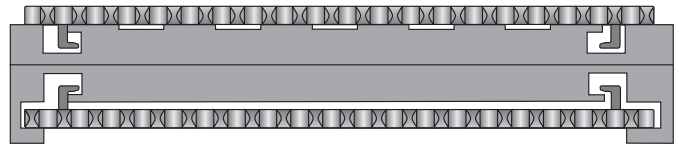

All Powerflex series with one TAB:

Supporting serpentine wearstrips are necessary



When a full curve is used, supporting return rollers or serpentine wearstrips are required for belts wider than 425mm.

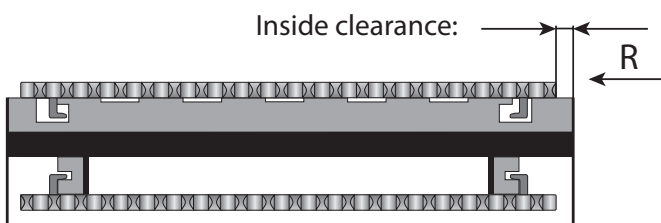
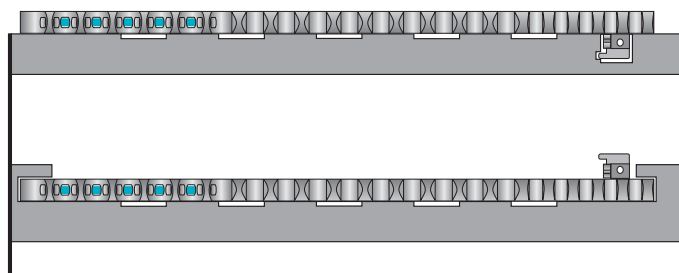
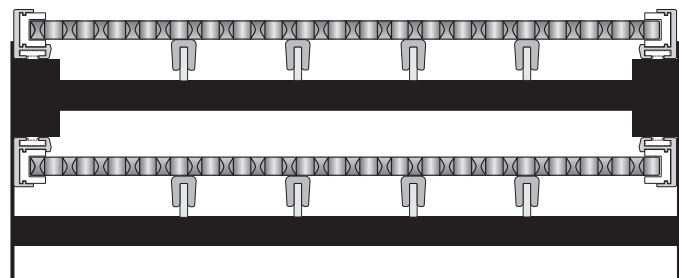
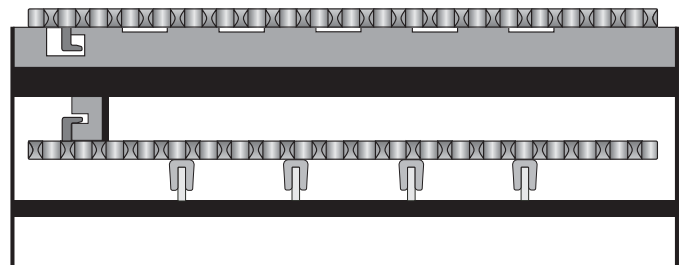

In any case, make sure that the belt does not touch the inner edge of the conveyor construction. A clearance of 10mm is recommended.

Since the belt is guided at the outside, any width expansion will be transferred towards the inside of the curve.

SIDEFLEXING BELTS

Guide profiles:

2351 and 2551:

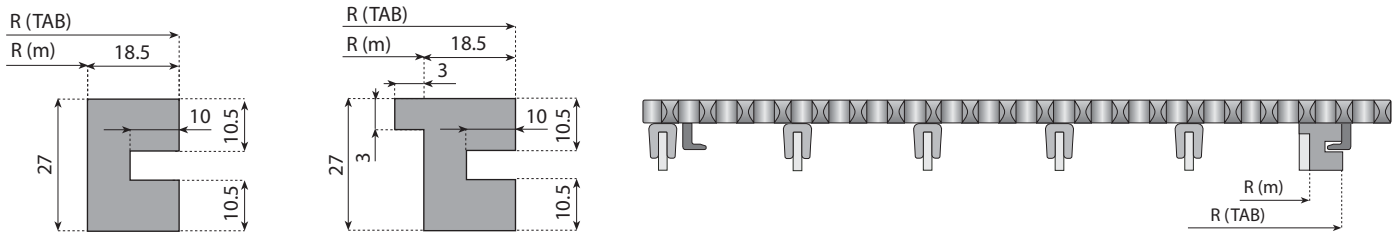

Width (W)	Min. radius for 2351		Min. radius for 2551	
	R (TAB)	R(m)	R (TAB)	R(m)
255	634.5	616	-	-
340	856.5	838	651.5	633
425	1076.5	1058	821.5	803
510	1321.5	1303	991.5	973
595	1546.5	1528	1161.5	1143
680	1801.5	1783	1331.5	1313
765	2036.5	2018	1586.5	1568
850	2271.5	2253	1871.5	1853

R(m) = outside edge of the mating part to which the guide profile is mounted

2451 and 2651:

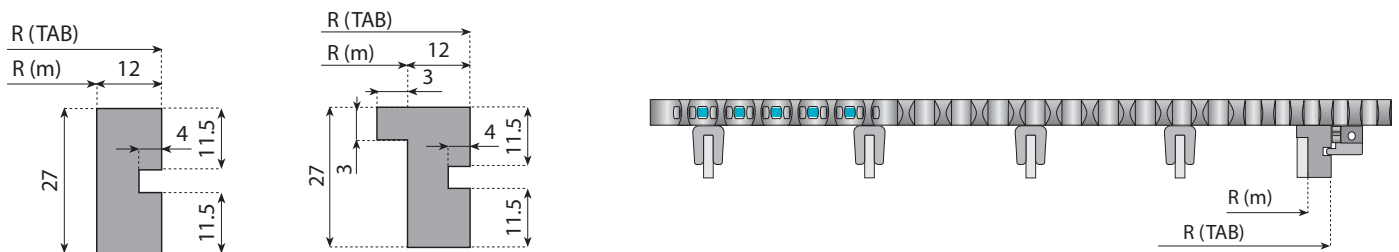

Width (W)	Min. radius for 2451		Min. radius for 2651	
	R (TAB)	R(m)	R (TAB)	R(m)
340	850	838	-	-
425	1070	1058	815	803
510	1315	1303	985	973
595	1540	1528	1155	1143
680	1795	1783	1325	1313
765	2030	2018	1580	1568
850	2265	2253	1865	1853

Sprocket positions and supporting wheels:

Since these belts are not symmetrical to the middle axis, please note that the precise sprocket position also depends on the running direction of the belt. The right position for both directions is given in the sketches below. For belt series 2451, 2551 and 2651 the offset must also be considered when the belt curve direction is changed (clock-wise / counter-clock-wise).

Note: Precise position of the sprockets must be determined during the installation to obtain optimum alignment.

2351 series:

Example 425 mm wide:
4 sprockets

Centre distance 85

First sprocket located at 80/90 mm from the edge.

Sprockets can be located over the whole width of the belt between the TABs.

 Indicates running direction

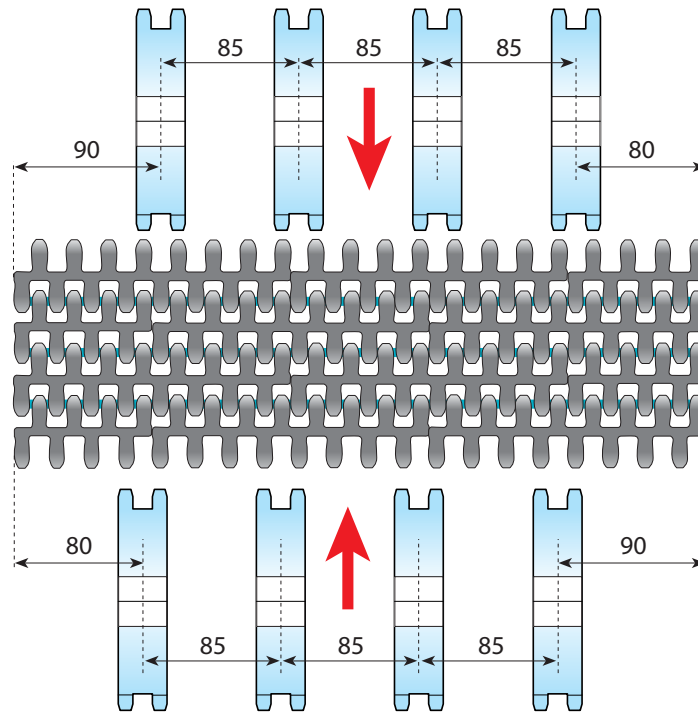

2451 series:

Example 425 mm wide:
4 sprockets

Centre distance 85

First sprocket located at 100/110 from the TAB-end edge.

Sprockets can be located over the whole width of the belt except of the 85 wide carry modules track.

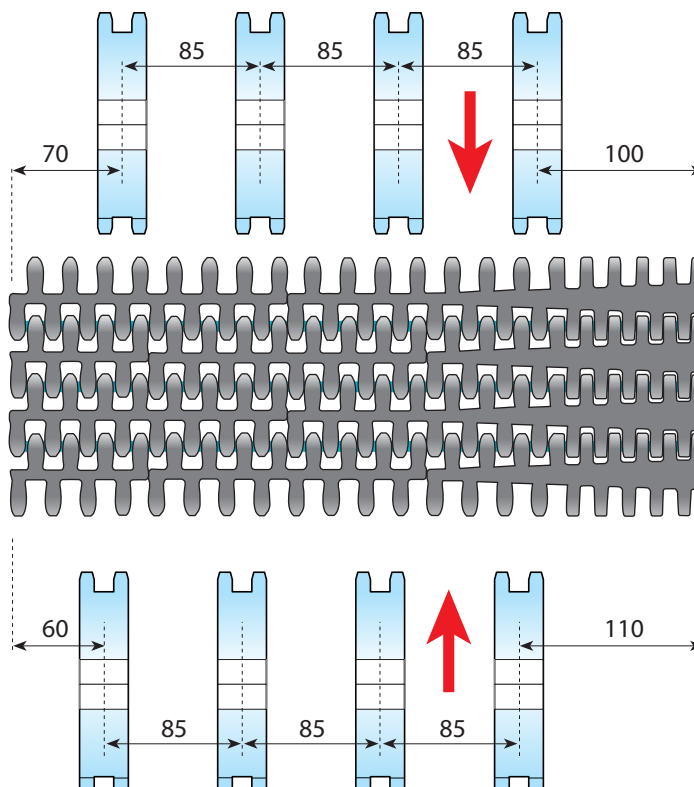

SIDEFLEXING BELTS

2551 series:

Example 425 mm wide:
3 sprockets

Centre distance 85

First sprocket located
at 80/90 from the
TAB-end edge.

'Zig-zag' small radius part
should be clear from
sprockets.

Sprockets can be located
over the whole width of the
belt between the TAB on
one side and the small radius
modules on the other side.

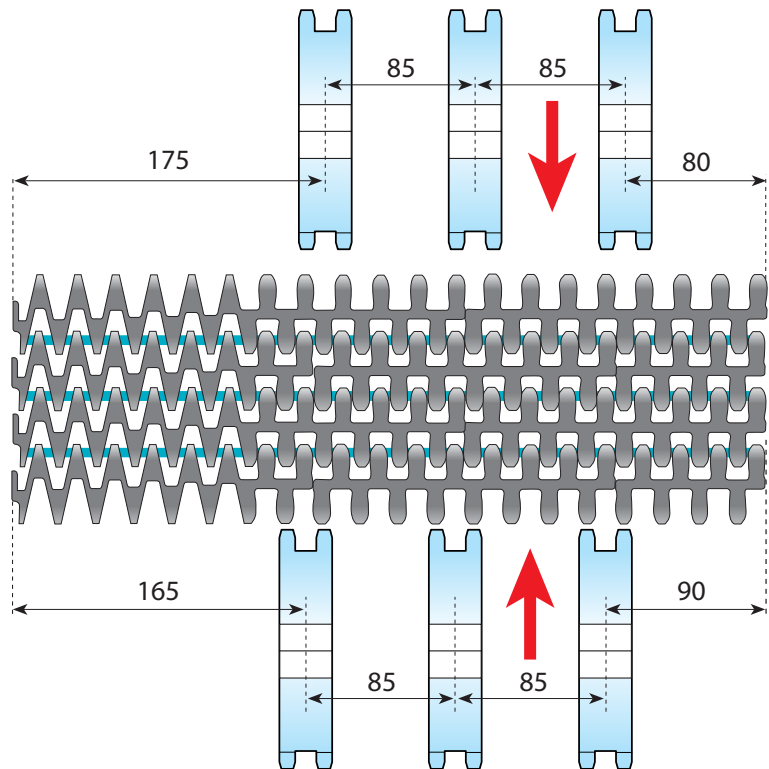

↓ ↑ Indicates running
direction

2651 series:

Example 425 mm wide:
3 sprockets

Centre distance 85

First sprocket located
at 90/100 from the
TAB-end edge.

Sprockets can be located
over the whole width of the
belt between the carry module
track one side and the small radius
module track on the other side

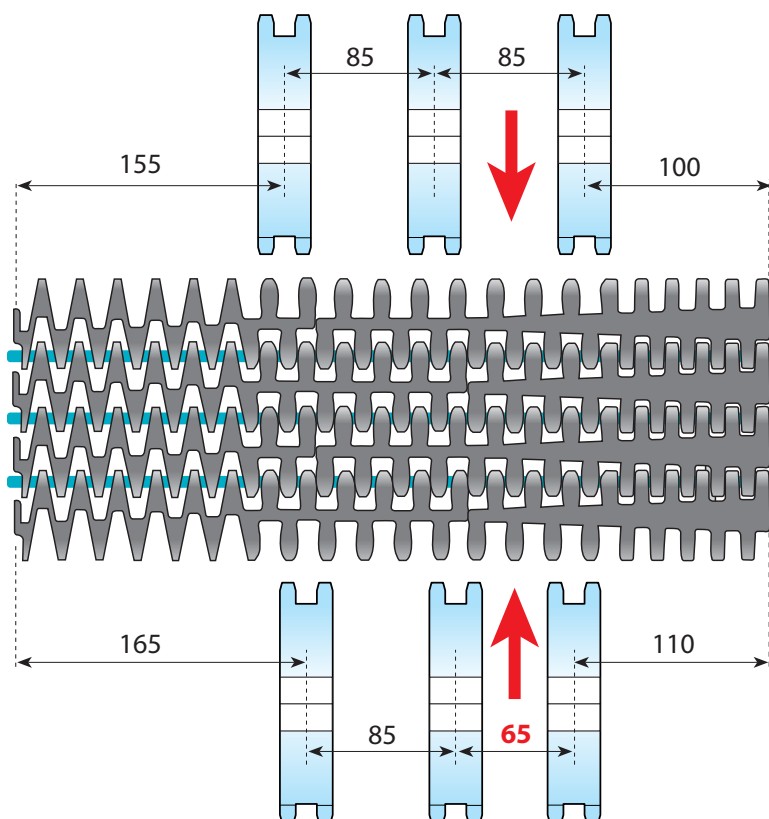

In case of interference with wearstrips other sprocket positions can be chosen. Please consult Technical Support for the available options.

Recommended number of sprockets and idler wheels, summary:

Width (mm)	series			
	2351	2451	2551	2651
255	2	-	-	-
340	3	3	2	-
425	4	4	3	3
510	5	5	4	4
595	6	6	5	5
680	7	7	6	6
765	8	8	7	7
850	9	9	8	8

Sprocket engagement and installation:



Sprockets engage on the curved end of the hinges. The teeth of the sprocket must push the highlighted surface of the hinges. That is important for the installation of sprockets.

Reverse operation:

Special sprockets can be supplied on request.

Middle/standard modules are designed for sprocket interaction. High torque transmission by means of optimized tooth geometry.

In order to avoid the belt from deflecting in areas where there's no sprocket, it is recommended to install a supporting wheel.

To calculate the diameter of the supporting wheel use the following rule:
 $D = C - 12.7$
 C = pitch circle diameter of the sprocket

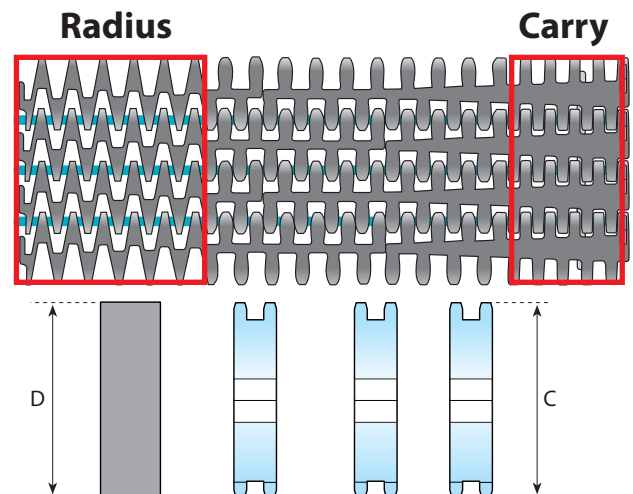

Fixed and floating sprockets:

It is recommended to fix the sprocket which is located closest to the outside track of the curving belt. The other sprockets can be floating using a 'Plus bore'. See further details in our Chains and Belts catalogue.

Drives:

End drives are the easiest way to drive the side flexing belts. However, centre drives are possible as well. For centre drives some special construction rules apply. Please refer to the relevant chapter in this manual.

For sprocket and idler dimensions the following is important:

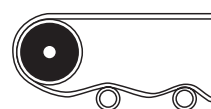
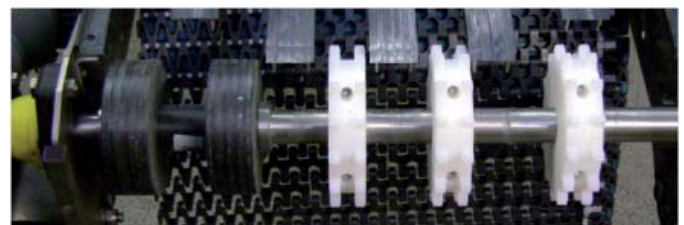

Smallest positive wrap around diameter: 60 mm

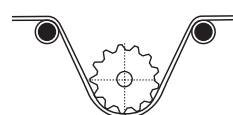

Smallest diameter of deflection roller: 80 mm

FlowFlex

2120M - 1/2" Side-Flexing chain-belt plus accessories

Design:

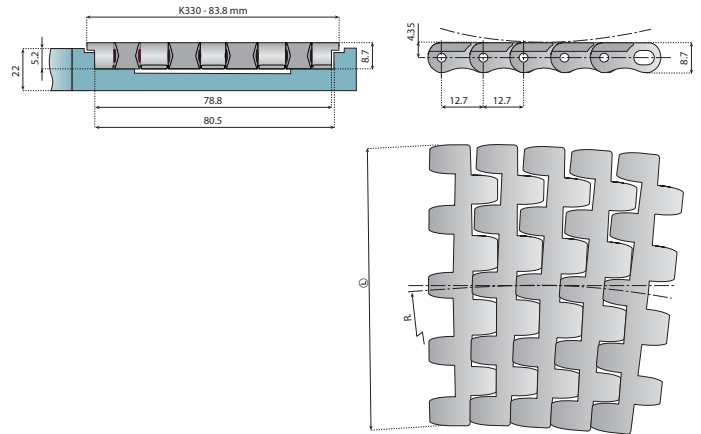

Plate thickness: 8.7mm

Pitch: 12.7mm (1/2")

Width: 83.8mm

Side-flex radius: 500mm

Radius underneath plate: 9.5mm

Track pitch system: 85mm

Curve retention system: magnetic

Materials: all plastic materials according to material table

Pins: stainless steel

Pin locking system: clip at one side

Other Features:

- Runs on the same sprockets as our straight running 1/2" belts (e.g. 2120).
- Runs nearly without polygon-effect around nosebars and idler shafts.
- Suitable for end drive as well as for centre drive.

Applications:

This side-flexing chain-belt was designed for applications that require a maximum of product support.

- Continuously running belt.
- Short head-to-tail transfers.
- Small gaps between adjacent tracks.

At the same time it was designed to reduce conveyor and maintenance costs.

- Less conveyor length.
- Less product guide length.
- Less required installation space.
- Less required time for conveyor conversions (product change).

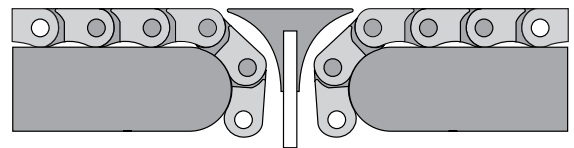

conventional layout

layout with flowflex

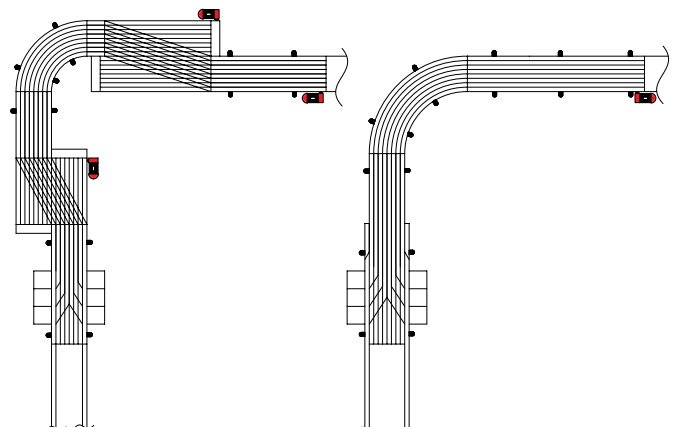



Side transfer



Linear transfer with FlowFlex



Side transfer



Linear transfer with FlowFlex

These features make this chain-belt suitable for a whole variety of applications.

- Difficult to handle products (non-cylindrical shape).
- Instable products (small diameter, high centre of gravity).
- Running a line empty.
- Low speed conveying as well as high speed single track conveying

Complete System:

The FlowFlex system contains:

- The chain-belt 2120M
- Sprockets out of the standard 2120 range
- Nosebars – see corresponding chapter in this engineering manual
- Magnetic curves – see corresponding chapter in this engineering manual

Conveyor Design for FlowFlex:

- Straight sections just require the standard conveyor design.
- The belt is sliding on the wear strips just like a modular belt.
- In order to guide the belt, wear strips with guide rail on top are recommended.
- For single track application the commonly used side-wear strips are recommended.
- For curving sections first of all our magnetic corner tracks are recommended. They fit exactly the chain-belt and offer maximum chain retention.
- Connection between curve and straight sections also require just the standard design.
- Return part design also just requires the standard design.
- Drive and catenary design is exactly like with straight running ½" belts.

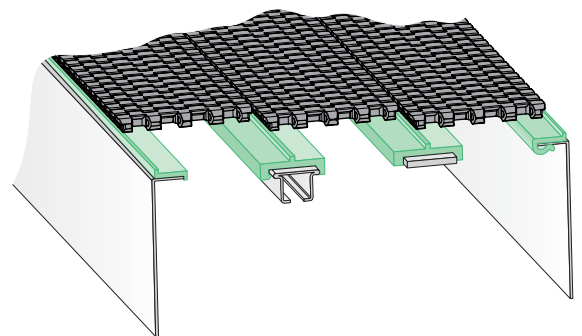

Product handling

Forces due to acceleration:

The force necessary to accelerate the chain and products is calculated by:

$$F = M * a$$

F= force in [N]

M= mass of chain and product in [kg]

a= acceleration in [m/s²]

This extra force is working not only on the chain but also on the bearings, the drive unit and the structure. Frequent start-stops create an extra fatigue load on the chain and thus shorten the life time of the chain. In the calculation there's a factor included depending on number of start-stops per hour. Soft starts or frequency controllers are always advisable. Not only for the life time of the chain but also for smoother product handling and avoiding problems at start-up with products particularly unstable.

Maximum acceleration:

The max acceleration force on a product to be able to 'take along' the product with the chain is depending on the friction between product and chain. Maximum acceleration a_{\max} can be calculated with:

$$a_{\max} = \frac{F_{\max}}{M} = \frac{W * \mu}{M} = \frac{M * g * \mu}{M} = g * \mu$$

W = weight of product in [N]

M = weight of product in [kg]

μ = coefficient of friction between chain and product

g = gravitational acceleration = 9.81 m/s²

Maximum force on products to avoid tippage:

The maximum acceleration without products falling over is depending on the shape (position of centre of gravity), the weight and the material of the product.

This is for instance also important when the product is being conveyed onto a dead plate.

See below sketch:

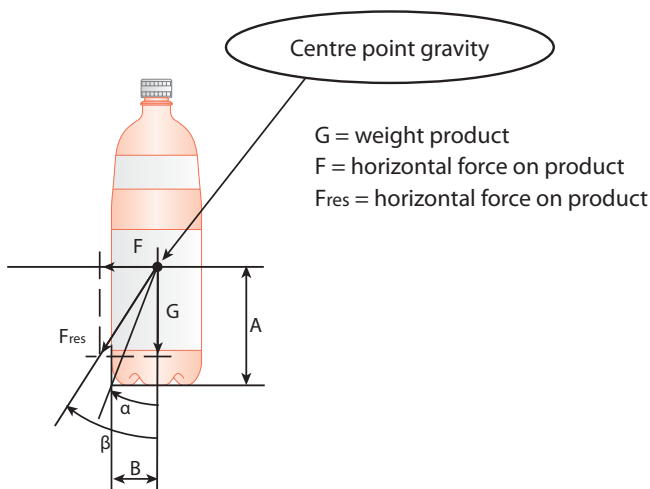

The force F is the force due to acceleration or deceleration of the product (F=M*a), or due to a different cause like other bottles or a side guide.

The bottle will tip over when the angle β is larger than angle α.

Angle α is determined by the diameter of the foot print of the product (B= ½ * diameter) and the height of the centre point of gravity (=A).

Angle β is determined by the horizontal force on the bottle (= F) relative to the weight of the bottle (= G).

The max force F is found by following formula:

$$\frac{F_{\max}}{G} = \frac{B}{A} \rightarrow F_{\max} = G * \frac{B}{A} \quad \text{or} \quad \begin{array}{l} \mu < \frac{B}{A} \longrightarrow \text{OK} \\ \mu > \frac{B}{A} \longrightarrow \text{not OK} \end{array}$$

MSV= maximum speed variation

$$MSV = \sqrt{2 * g(\sqrt{H^2 + B^2} - H)}$$

Centrifugal forces:

When a product is being conveyed through a curve there's a centrifugal force working on the product. This force on the product is compensated by the friction between chain and product and by a side guide.

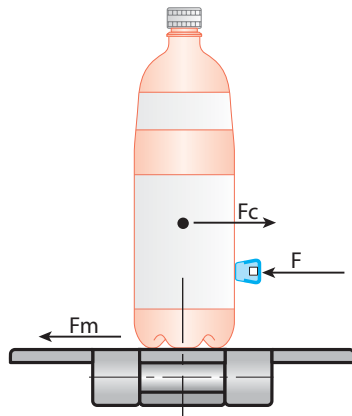

The centrifugal force is calculated with:

$$F_c = \frac{M * v^2}{r}$$

M= weight of the product

v = speed

r = centre radius of the curve

Friction force between chain and product is calculated with:

$$F_m = M * g * \mu$$

g = gravitational acceleration

μ = coefficient of friction between chain and product.

The minimum force F that needs to be generated by the side guide is:

$$F = F_c - F_m = M * \left[\frac{v^2}{r} - g * \mu \right]$$

Pressure of accumulating products:

When a product is standing still (e.g. against a stopper or guide), the chain running underneath the product creates a force on the product equal to the weight of the product multiplied by the coefficient of friction between chain and product.

Each following product is pushing with the same force against the next product, so the resulting force is proportional to the total weight of products upstream.

$$F_a = W_a * L_a * \mu$$

F_a = accumulation force

W_a = weight of the accumulating products in Kg/m.

L_a = length of accumulation in m

μ = coefficient of friction between chain and product.

Side transfer action:

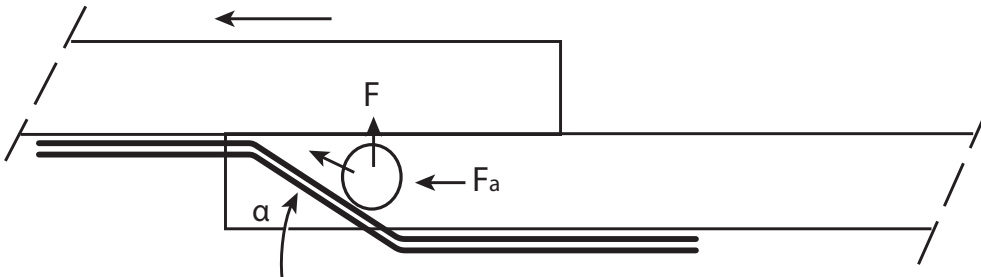

Pushing the product sideward creates a force F on the product against the side guide.

$$F = F_a * \sin(\alpha) = W_a * L_a * \mu * \sin(\alpha)$$

(see explanation of symbols above)

Nowadays cans and bottles are becoming thinner and thinner. At the same time more and more installations are running with less or no lubrication and thus increasing the coefficient of friction. That's why it's important to take also these forces on the products into consideration.

In the above mentioned formula the angle α plays an important role in a smooth transfer and reduced forces on the products. This angle should be kept as small as possible.

90° product transfer:

When transferring products from one conveyor to another at 90° angle, it's common practice to use full radius guide rails with dead plates which span the space between the infeed and outfeed conveyors. Products moving along the full radius guide rail exert high pressure on the rail and on each other, easily resulting in damage.

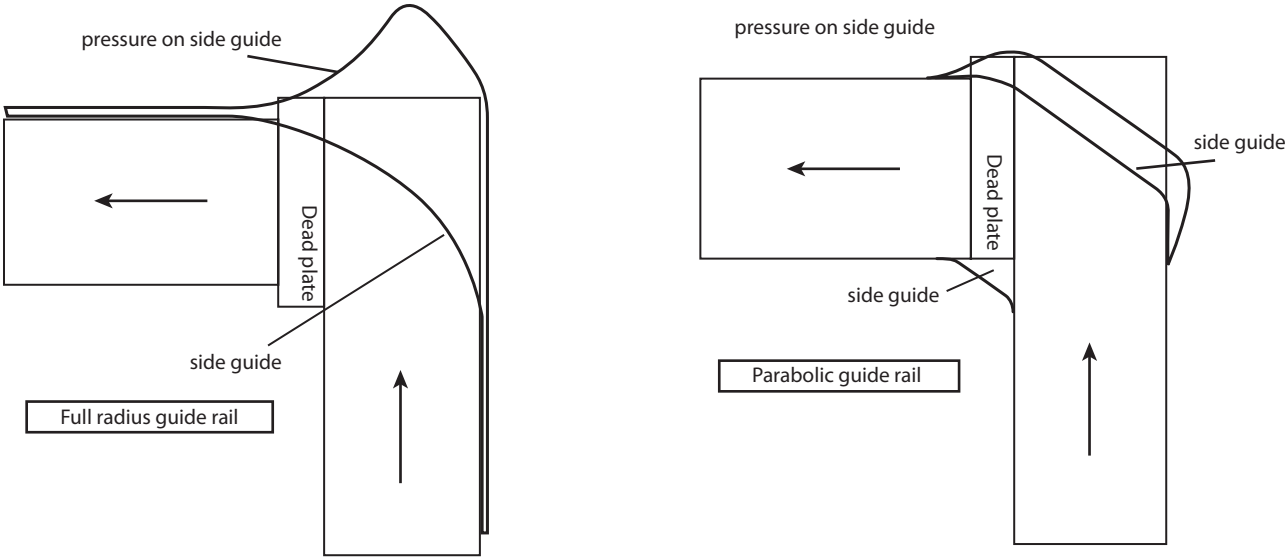

The parabolic guide rail distributes the pressure better along the outer guide rail. This results in significantly less potential for damage on products. However on the inside of the curve extra room must be created for a 'dead area'. The use of the Systemplast active transfer wing system will eliminate the dead plate and further reduce the pressure on products and side guides.

Bearings and shafts

Forces on bearings and shafts:

After calculating the pull force at the drive end per strand of chain, we can calculate the total pull on the shaft T_s . If we look at the setup with the drive unit above the conveyor with a roller chain transferring the power to the drive shaft the field of forces looks like:

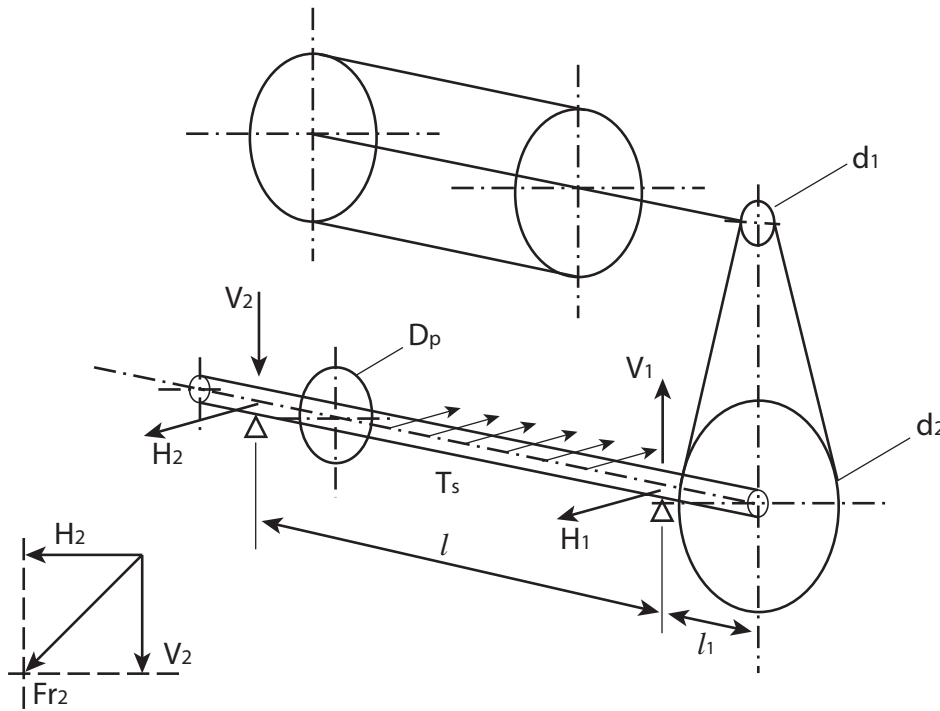

- H = Horizontal force
- V = Vertical force
- $H_1 = H_2 = T_s/2$
- Drive ratio $R = d_1/d_2$
- $V = T_s * (D_p/d_2)$
- D_p = sprocket pitch diameter
- $V_1 = V + V_2$
- $V_2 = V * (l_1/l)$
- T_s = Total pull

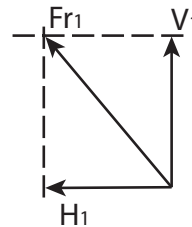

F_{r1} gives the highest load on the bearing on the side of the drive unit and can be calculated from V_1 and H_1 :

$$F_{r1} = \sqrt{H_1^2 + V_1^2} = \sqrt{\left[\frac{T_s}{2}\right]^2 + T_s^2 * \frac{D_p^2}{d_2^2} * \left[1 + \frac{l_1}{l}\right]^2} \quad [N]$$

If the specific conveyor has a head-to-tail transfer you can include the weight of the products in the vertical load on the shaft. However normally speaking this load is relatively low compared to the load generated by T_s .

Shaft size:

The shaft must fulfil the following conditions:

- max shaft deflection under full load (F_w). f_{max} is 2.5 mm. If the calculated shaft deflection exceeds this max value, select a bigger shaft size or install an intermediate bearing on the shaft.
- Torque at max load must be below critical value

Shaft deflection can be calculated with following formula:

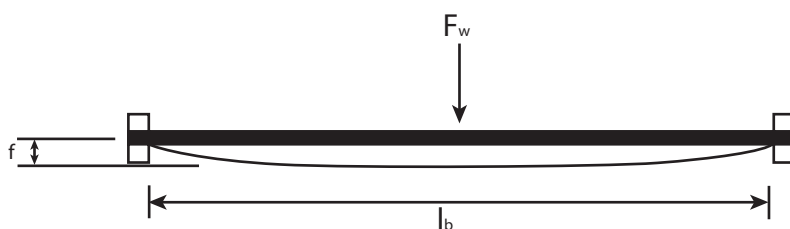

2 bearings: $f = 0.013 * F_w * \frac{l_b^3}{E * I}$ [mm]

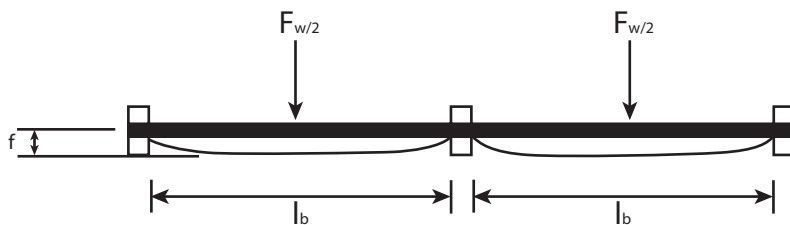

2 bearings: $f = \frac{1}{370} * F_w * \frac{l_b^3}{E * I}$ [mm]

- For uni-directional head drive $F_w = T_s$
- For bi-directional centre drive $F_w = 2 * T_s$
- For uni-directional pusher drives $F_w = 2.2 * T_s$

GENERAL CALCULATION

Shaft size [mm]	Inertia [mm ⁴]
Ø20	7850
Ø25	19170
∅25	32550
Ø30	39751
Ø35	73643
Ø40	125660
∅40	213330
Ø60	636170
∅60	1080000
Ø90	3220620
∅90	5467500

Shaft materials	Modulus of elasticity E	Shearing strength	Possible material specifications
	[N/mm ²]	[N/mm ²]	
Carbon steel	206000	60	St 37-2, St 37
Stainless steel (low strength)	195000	60	X5CrNi18 10, AISI 316, 304
Stainless steel (high strength)	195000	90	X12CrNi17 7, AISI 301
Aluminium	70000	40	AlMg, AA 5052

The torque on the shaft is calculated with:

$$T_{\max} = F_w * \frac{d_p}{2} * 10^{-3} \quad [\text{Nm}]$$

T_{\max} = maximum torque
 T_{adm} = admissible torque

$$T_{\text{adm}} = \eta_{\text{adm}} * \frac{d_w^3}{5000} \quad [\text{Nm}]$$

η_{adm} = admissible shearing strength [N/mm²]

for max. admissible shearing strength see table below:

Maximum allowable torque		
Shaft diam. [mm]	Carbon steel [Nm]	Stainless steel [Nm]
Ø20	94	141
Ø25	184	276
Ø30	318	477
Ø40	754	1131
Ø45	1074	1610
Ø50	1473	2209
Ø55	1960	2940
Ø60	2545	3817
Ø80	6032	9048
Ø90	8588	12882

Bearing calculations for series UC and UF:

Static load calculation:

In case the bearing is loaded without rotating, very slowly rotating or is making a slow oscillating movement the bearing power is not determined by the fatigue life of the material but by the deformation of the rollers and the groove.

This calculation is also valid if at a fraction of the rotation a shock load is present.

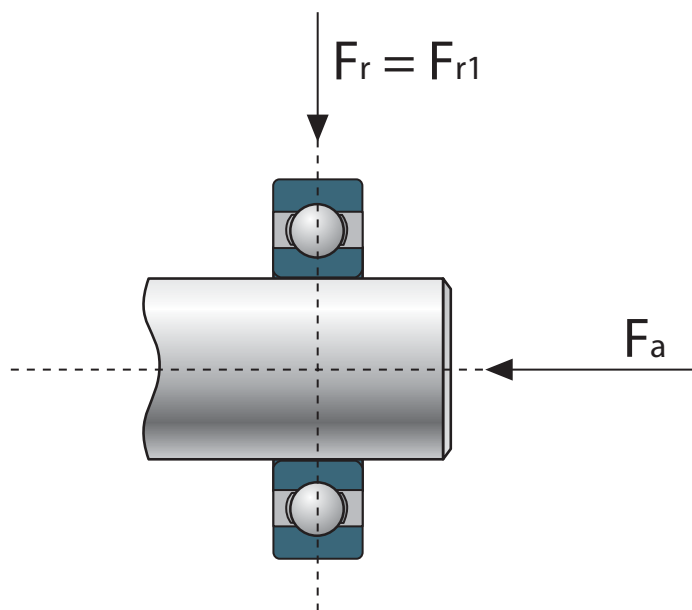

$$P_0 = X_0 * F_r + Y_0 * F_a$$

$$= 0.6 * F_r + 0.5 * F_a$$

P_0 = equivalent static load [N]

X_0 = radial static factor

F_r = radial load [N]

Y_0 = axial static factor

F_a = axial load [N]

P_0 is calculated when there is not only a radial component in the load but also an axial component. When the load on the bearing is strictly radial the equivalent static load $P_0 = F_r$.

The minimum static load coefficient C_0 is calculated taking into account the static safety factor S_0 . Then in the bearing tables the right size bearing can be found checking the C_0 .

$$C_0 = s_0 * P_0$$

C_0 = static load coefficient in [N]

S_0 = static safety factor = 1 for normal circumstances

= 1.5 when vibrations are involved

= 2-2.5 for noiseless applications.

GENERAL CALCULATION

Dynamic load calculation:

For normal circumstances the dynamic load coefficient is calculated and compared to the equivalent dynamic load to determine the theoretical life time of the bearing.

The calculated life time is then compared to the standard for the application and industry.

According to ISO 281, the dynamic load coefficient indicates the bearing load under which the bearing will last at least the nominal $1 \cdot 10^6$ rotations. Taken the load is constant and radial.

$$L_{10} = \left(\frac{C}{P} \right)^3$$

L_{10} = nominal life time in millions of revolutions

C = dynamic load coefficient in [N]

P = equivalent dynamic load [N]

When the load on the bearing is strictly radial the equivalent dynamic load $P = F_r$.

When there's also an axial load involved the equivalent dynamic load is:

$$P = X * F_r + Y * F_a$$

X = radial dynamic factor

Y = axial dynamic factor

The axial force only influences the equivalent dynamic load when $F_a / F_r > e$

Calculation factors					
		$F_a / F_r < e$		$F_a / F_r > e$	
F_a / C_0	e	X	Y	X	Y
0.025	0.22	1	0	0.56	2
0.04	0.24	1	0	0.56	1.8
0.07	0.27	1	0	0.56	1.6
0.13	0.31	1	0	0.56	1.4
0.25	0.37	1	0	0.56	1.2
0.5	0.44	1	0	0.56	1

The axial load should never exceed 20% of C

For the **support series F and FC** carrying the double row roller bearings 1205 -1208 the calculations are as follows:

Combined static load:

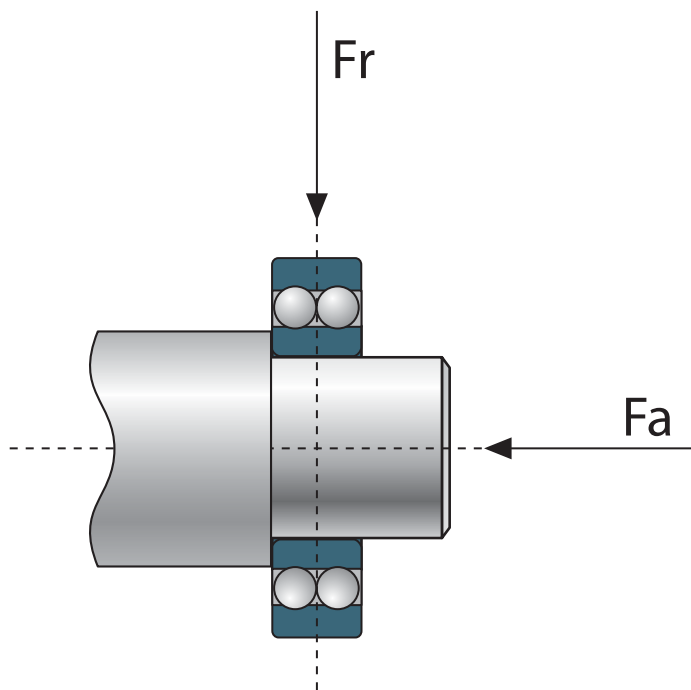

$$P_0 = F_r + Y_0 * F_a$$

Combined dynamic load:

When $F_a/F_r < e \rightarrow$

$$P_0 = F_r + Y_1 * F_a$$

When $F_a/F_r > e \rightarrow$

$$P_0 = 0.65 * F_r + Y_2 * F_a$$

Bearing type	e	Y ₀	Y ₁	Y ₂
1205	0.28	2.4	2.3	3.5
1206	0.24	2.8	2.6	4.1
1207	0.23	2.9	2.7	4.2
1208	0.22	3	2.9	4.4

Indicative speed for shaft tolerances:

Shaft diam. [mm]	h6	h7	h8	h9	h11
	rpm				
Limiting speeds - Shaft tolerance					
12	9500	6000	4300	1500	950
15	9500	6000	4300	1500	950
16	9500	6000	4300	1500	950
17	9500	6000	4300	1500	950
20	8500	5300	3800	1300	850
25	7000	4500	3200	1000	700
30	6300	4000	2800	900	630
35	5300	3400	2200	750	530
40	4800	3000	1900	670	480

Relubrication is depending on the operating conditions. Dust, load, humidity, temperature, vibrations: all affect the relubrication interval. Below table show indicative values for relubrication intervals.

Please note that all our bearing are pre-greased in the factory. There is no need for immediate re-greasing. Furthermore, regreasing should be done in small amounts and with care.

Use conditions	Temperature	Re-lubrication period
Clean	up to 50°C	1-2 years
Clean	50 ÷ 70 °C	4 -8 months
Clean	70 ÷ 100 °C	1 - 3 months
Dirty	up to 70°C	2 - 8 week
Dirty	70 ÷ 100 °C	2 - 4 week
Humid + wet	-	1 - 2 week

Speedset

A few things should be taken into consideration when mounting and using Speedset to get full benefit of its features:

- easy and accurate setting of different positions of the side guides;
- avoid product damage;
- increase the line efficiency.

Content:

- 1) The system`
- 2) Positioning the Speedset units
- 3) The spacer
- 4) Transfers
- 5) Guide rail radius
- 6) Further considerations

THE SYSTEM:

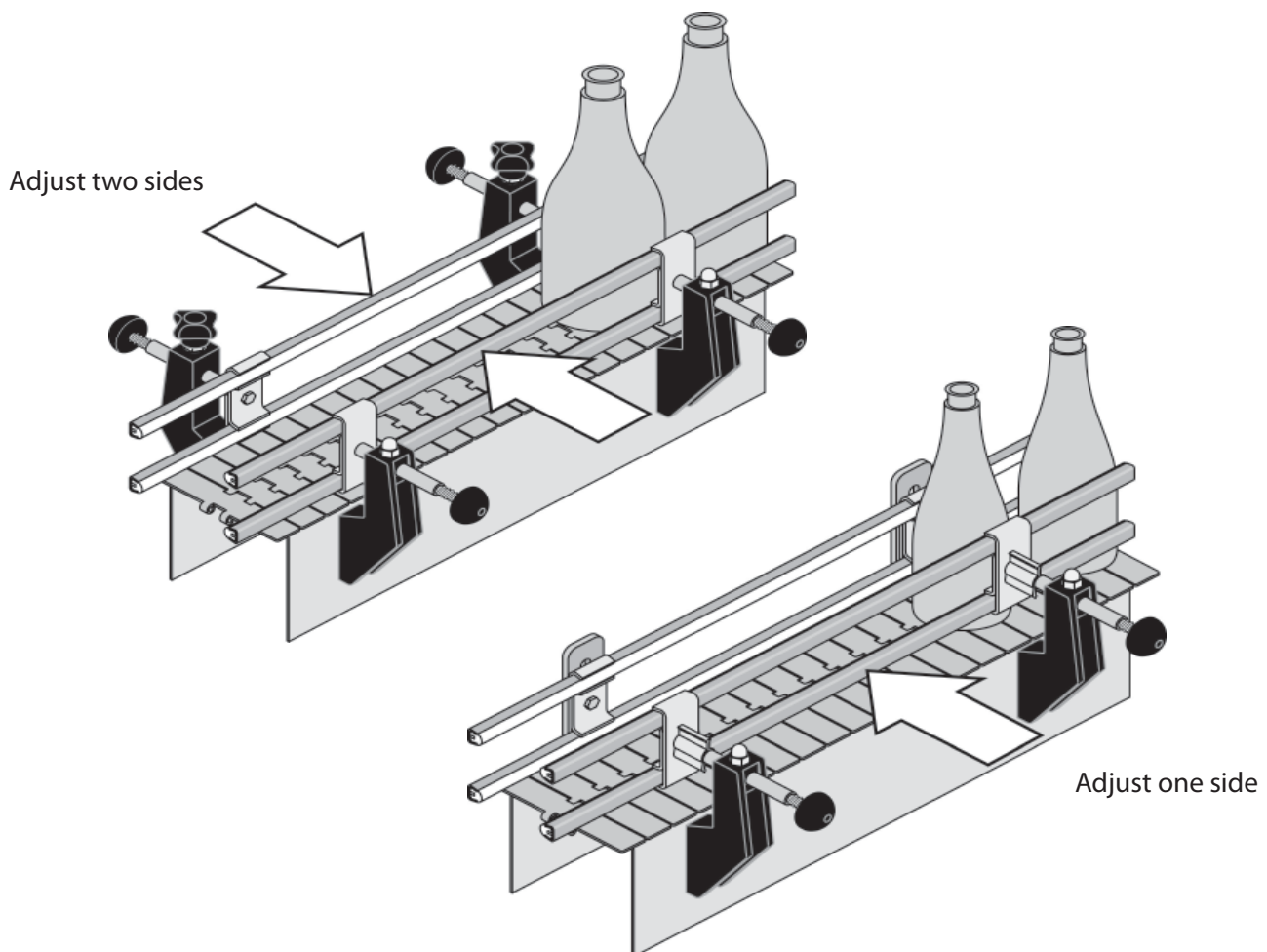

Single side adjusting

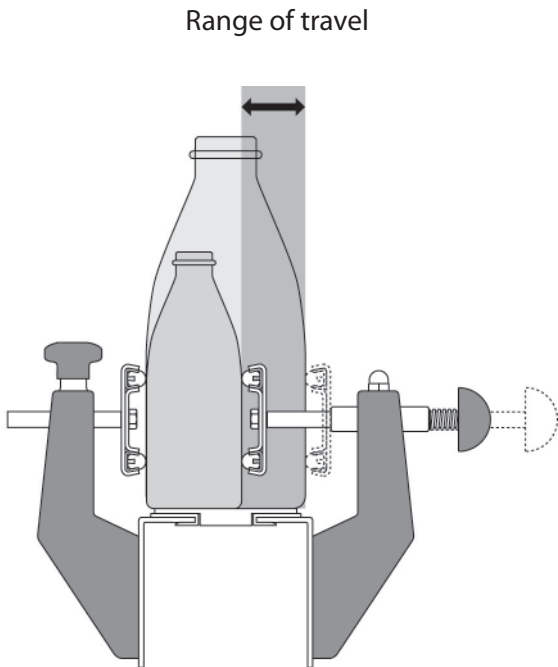

Double side adjusting

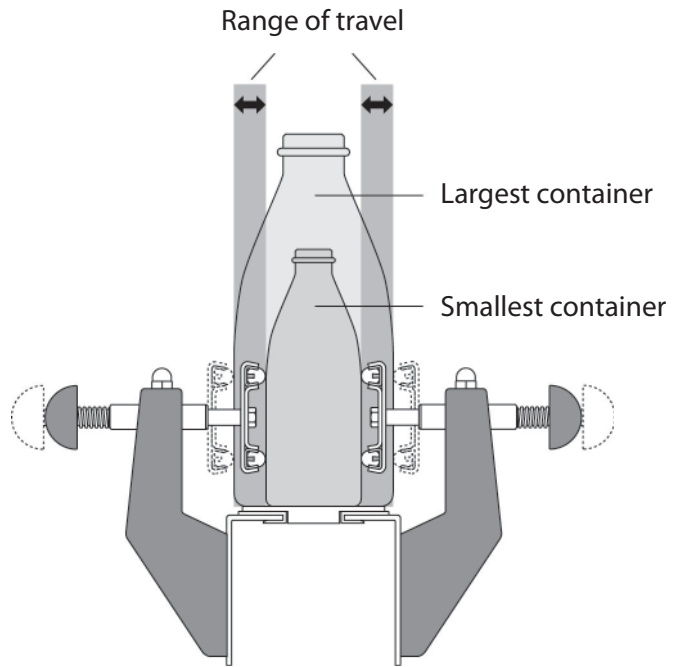

The Speedset system is available in three maximum travel distances:

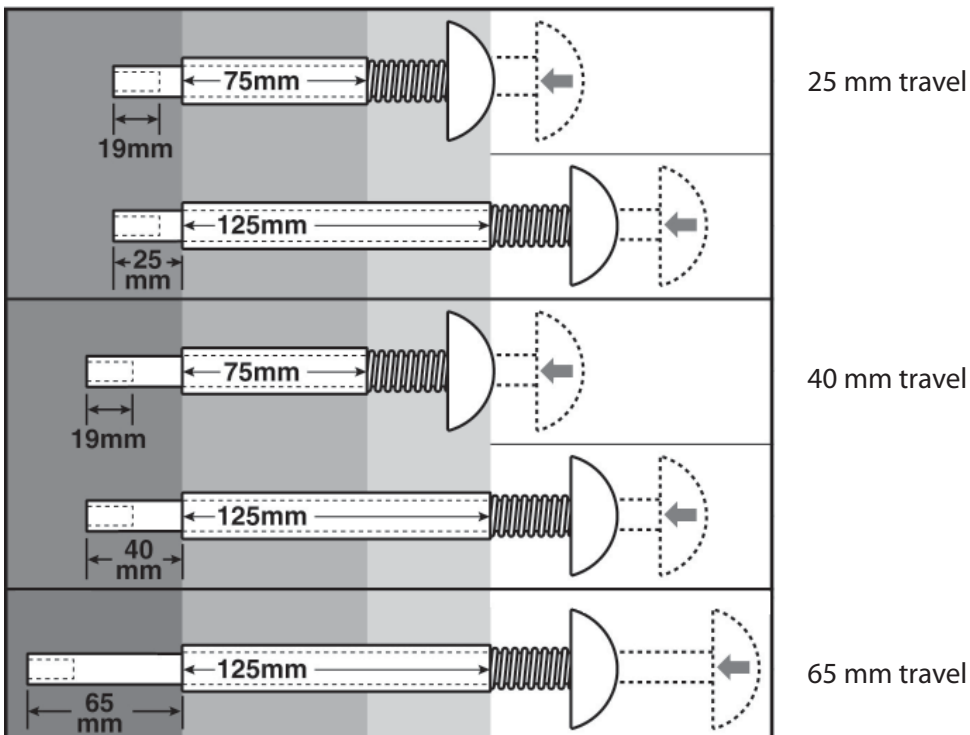

There are three different spacer types: QSC, QSB and QPC

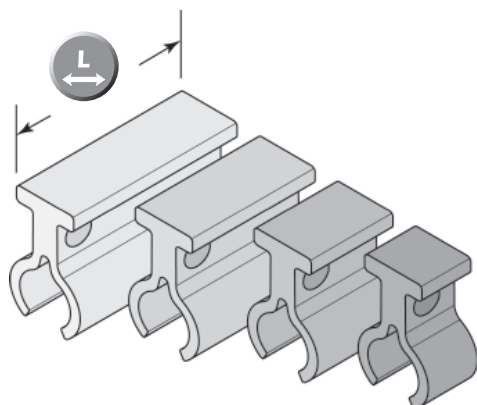

QSC-COLOR CLIP

Can be connected to the bracket or the machine with the VG-QT rope.

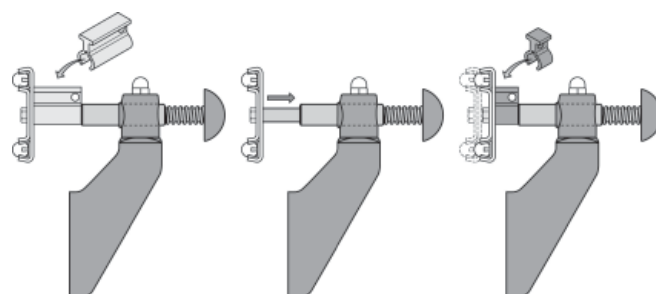

Code	Ref.	L		
13S00292	VG-QSC-10M	10 mm	n°10	Red
13S00293	VG-QSC-12M	12 mm		Blue
13S00294	VG-QSC-16M	16 mm		Black
13S00295	VG-QSC-20M	20 mm		Green
13S00296	VG-QSC-25M	25 mm		Purple
13S00297	VG-QSC-30M	30 mm		Orange
13S00298	VG-QSC-40M	40 mm		Gray

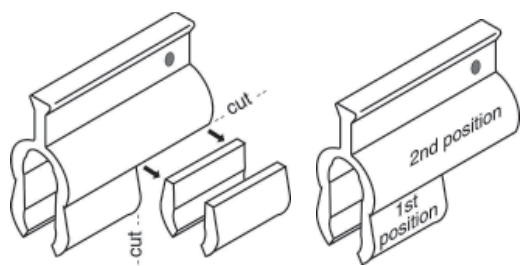

QSB - CLIP ON SPACER

Cut to length as needed. Can be connected to the bracket or the machine with the VG-QT rope. Also available in bars of 450 mm.

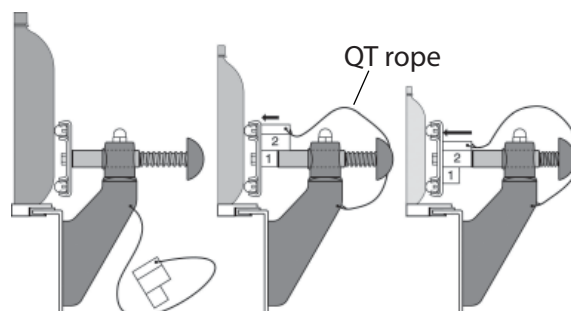

Code	Ref.	L	
13S00288	VG-QSB - 25M	25 mm	n°10
13S00289	VG-QSB - 40M	40 mm	n°10
13S00291	VG-QSB - 65M	65 mm	n°10
13S00290	VG-QSB - 450M	450 mm	n°1

13S00299	VG-QT-01	225 mm	n°10
----------	----------	--------	------

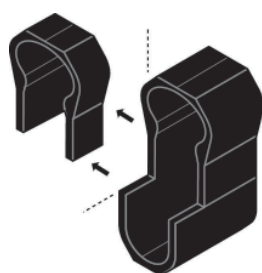

QPC - COLLAR POSITIONING SPACER

Cut to length as needed. Hangs free on the pin when not in use. Available in 450mm lengths.

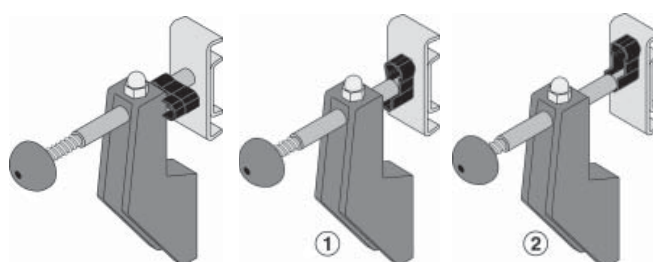

Code	Ref.	L	
13S00288	VG-QSB - 25M	25 mm	n°10
13S00289	VG-QSB - 40M	40 mm	n°10
13S00291	VG-QSB - 65M	65 mm	n°10
13S00290	VG-QSB - 450M	450 mm	n°1

Speedset in the curve:

Speedset can also be used in curves. It should be taken into consideration that the guide rail in the curve is a separate piece from the guide rail on the straight end. Also an extra hinge must be used and brackets with a swivel head to be able to mount the Speedset units parallel also in the curve. The Speedset units must be parallel to be able to adjust them.
See sketch underneath.

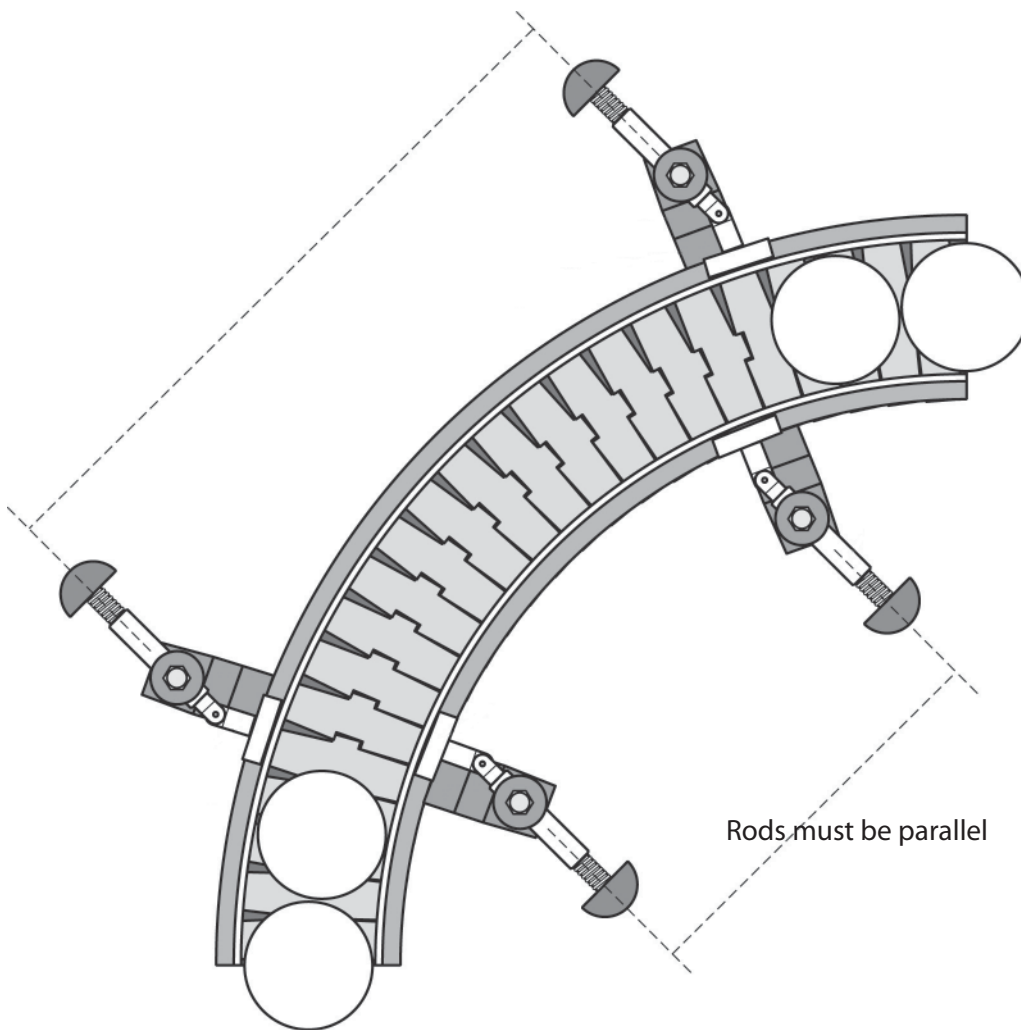

The position of the speedset units:

Important is the distance between the brackets of minimum 800-1000 mm, depending on the flexibility of the guide rail and the brackets. The system of Speedset is designed in a way that you can walk alongside the conveyor and change the position of the guide rail bracket after bracket. That means you need enough flexibility to reset the Speedset units one after the other. Speedset has limited flexibility in itself because it also needs to hold the side guide.

Also the stiffness of the bracket influences the flexibility of the whole system. That's why we recommend using the standard 213 (e.g. 13S00009) or 223 (e.g. 13S00042) stainless steel brackets.

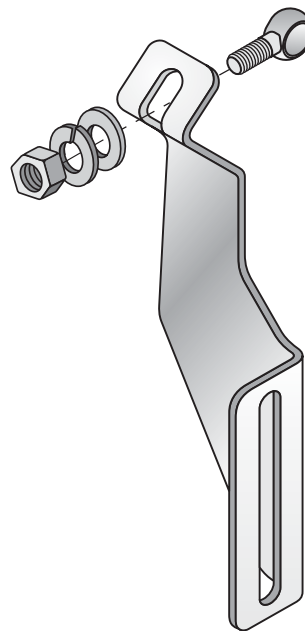
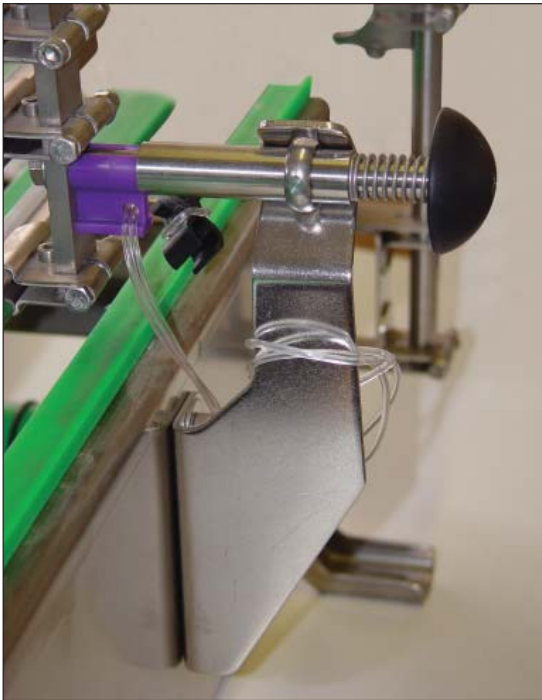

Always use a nut instead of a knob to fasten the Speedset unit in the bracket because the absolute position –once set- should not be changed anymore. In this way undeliberate false settings are avoided.

When the guide rail goes across a sideward transfer, the rail itself can be of 1 piece because the Speedset units remain parallel. But the Speedset units should always be positioned before or after the transfer where the guide rail is straight and not bent.

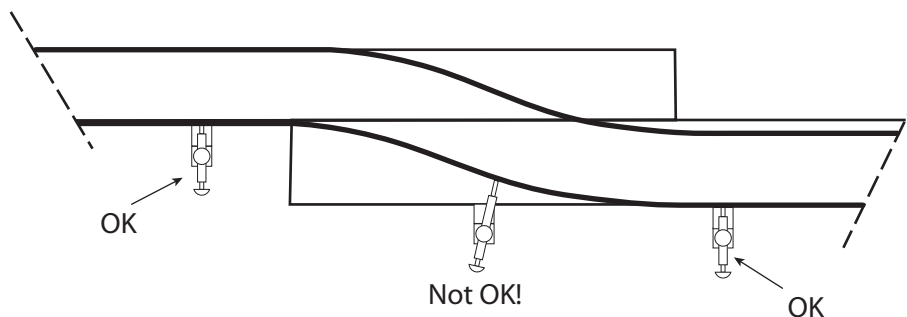

When positioning the Speedset units it should also be taken into consideration that you need some room around the Speedset unit for your hands to make the setting of the different positions.

Important for sufficiently free moving of the Speedset units is the alignment of the clamps on the guide rail with the brackets on the side of the structure.

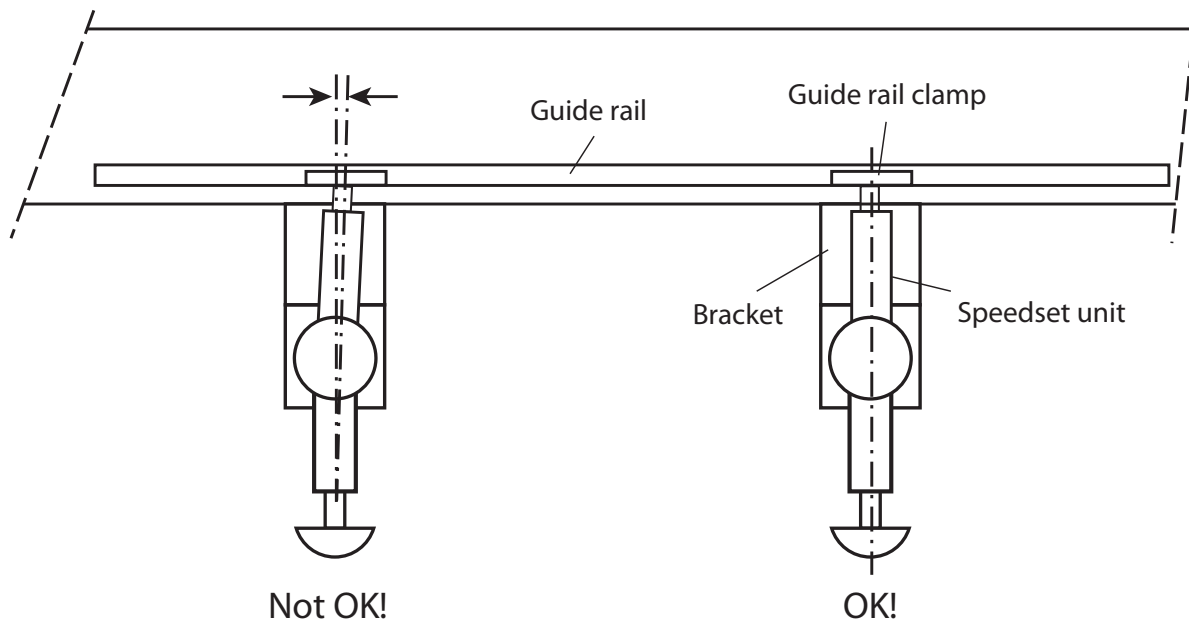

In short: the Speedset units should be parallel with sufficient distance and well aligned with the clamps holding the guide rail. The Speedset units must have enough room to move. The guide rail itself needs to be stable, straight and/or bent properly. Instead of fixing everything as much as possible you need to give room for movement.

The spacers:

A key element of the Speedset system are the spacers. They set the relative position of the guide rail.

The spacers for Speedset are supplied uncut at the standard length corresponding to the maximum travel distance of the Speedset unit (25, 40 or 65mm). The QSC style spacer is available in different lengths and different corresponding colours. Of the QSB and QPC style spacer, there's also a 450 mm version available to cut intermediate lengths more efficiently.

The QSC style spacers have the advantage that they have fixed colours which can be used for easy reference of the different positions.

The black QPC style spacer has the advantage that it hangs around the Speedset unit. Three positions can be made with the QPC style spacer per side. More positions can be set with the QSB and QSC. These spacers can be hung at the bracket with the PVC QT rope in order not to lose them.

The total Speedset unit is fixed with an eyebolt and nut. The absolute position is set with this eyebolt/nut. With the spacers the relative position is determined. The length of the spacers or the length of the corner to be cut out of the QPC spacer depends upon the difference in diameter between the products on the line.

Example using the QPC spacer, single side adjusting:

Note that the corner to be cut out is on the side where the spacer is wider. See picture below.

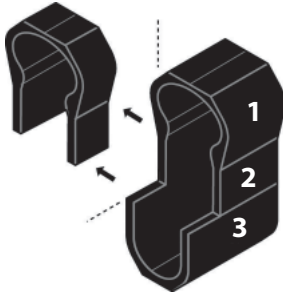

Bottle diameters: 54, 62 and 89 mm.

The maximum difference is 35 mm (89-54). This requires the Speedset unit with a max. travel distance of 40 mm. The first position (marked 1 in the above picture) using the QPC spacer is in fact using it without the spacer. The second is half way (marked as 2 in the above picture) and the third is at the outer end (marked 3 in the above picture).

The first position without the spacer is for the largest bottle. Setting the Speedset units always goes from the outside to the inside.

The relative difference between the first and second position is $89-62 = 27$ mm. The relative difference between the first and third position is $89-54=35$ mm. This means that the total thickness of the spacer is 35 mm.

The standard spacer which comes with the Speedset unit of 40 mm travel distance is also 40 mm and needs to be cut to 35mm.

Then the corner needs to be cut out for the second position. The part of the spacer that stays needs to be 27 mm. That means that the corner which should be cut out is $35-27 = 8$ mm (don't forget to calculate with the blade thickness of the cutter).

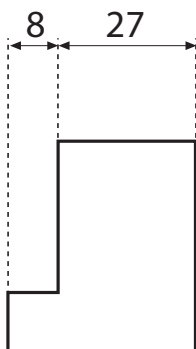

On request also special QPC spacers are available when the difference between the first and second position (between the largest and second largest bottle) is less than 5 mm.

Contact Technical Support for advise on that situation.

Being able to accurately set the position of the guide rail on the straight end as well as in the curve brings us automatically to the next two questions:

What about the transfers at the entry and exit of the curve?

And what about adjusting the radius of the guide rail in the curve?

Transfers:

Guide rail transfers in/out curve:

If we take a conveyor section with a 90° curve. The curve section will be moved back and forth under a 45° angle. See below:

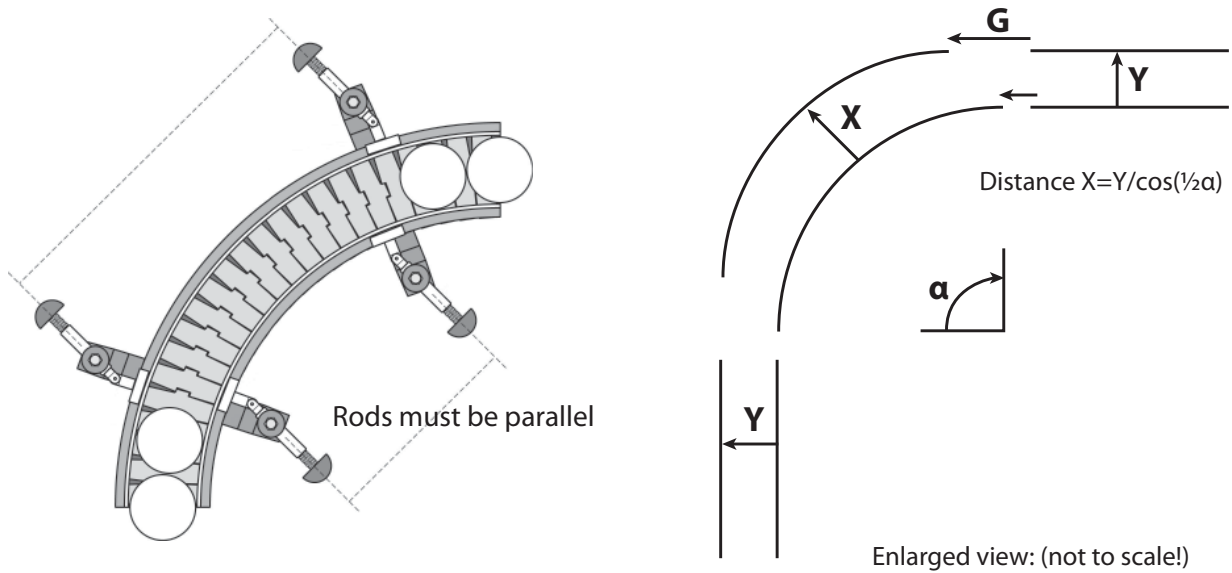

This means that the outside curve section moves away from the straight section when shifted to the outside (larger product diameter). Gap G needs to be covered to ensure a smooth product guiding.

To cover gap "G" there are standard kits available like code 131170:

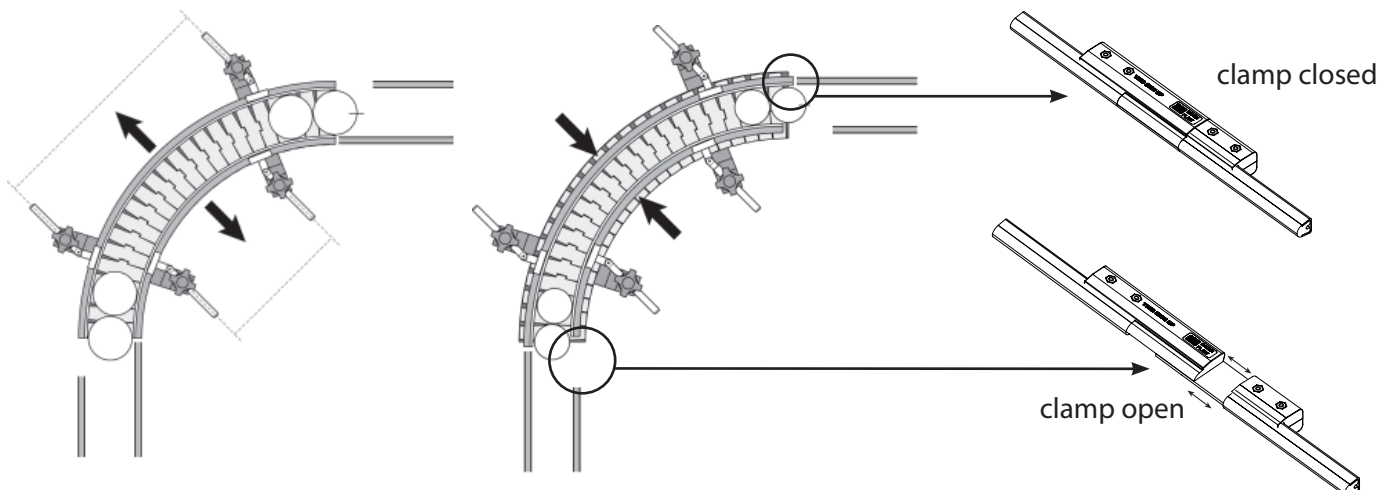

We always recommend to make the transfer from the straight section to the curve section and back about 100-200 mm before and after the curve (100-200mm straight at the in- and outfeed of the curve)

If the guide rail has sufficient height, cutting it under -for instance- a 30° angle will give in most cases enough horizontal room to cover the gap in the outer (widest) position of the guide rail. In this way the product will always be guided. This is an alternative to the method on page 89.

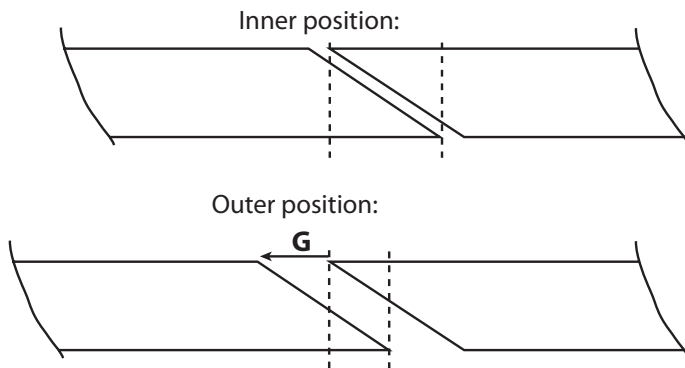

For more extreme differences in product diameter we advise to contact technical support.

Radius of guide rail:

In theory when adjusting the guide rail in a curve you would want to also adjust the radius of the guide rail.

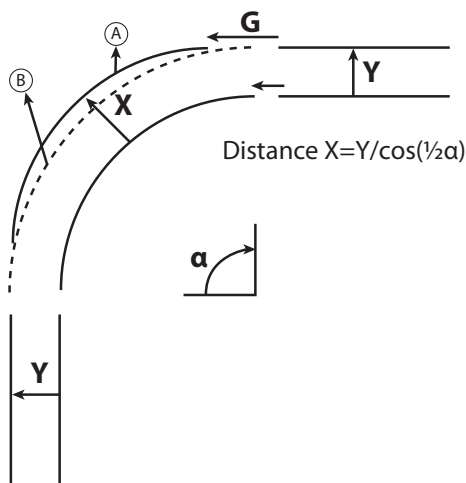

Instead of the guide rail radius A you would theoretically want radius B.

In practise however this is hardly ever an issue because the guide rail itself needs to be stable and is -partly- made of stainless steel. Therefore you cannot change the radius.

Also the differences in product diameter tend to be relatively small, so the difference in radius is also small.

If (like just in front and after the machines) the product needs to be guided on the centre of the chain the difference is divided between left and right and thus even less.

In practice these differences are ignored. Important thing is to set the transfers right.

If for whatever reason it is necessary to adjust the radius a few options are possible.

1. Guide rail with the stainless steel backing (like the 19019) only where the clamps are. The rest is plastic only and thus flexible. This is only possible with light weight products.
2. In the case of roller guides, the flexible Speedrail (16S00300) can be used.
3. Any other flexible and still sufficiently stable custom built guide rail.

Depending on the radius of the curve 2 or 3 brackets are supporting the guide rail. For adjusting also the radius you need at least 3 brackets. The 2 outer set the distance. The one in the middle determines the radius.

Further considerations:

The most important thing is to realize that there is a different thought behind Speedset than with the usual fixed side guide. The usual fixed side guide is kept in place by the stiff and rigid brackets and nuts/knobs. The accuracy is less important because the guide rail can always be forced into position by the rigid brackets.

With Speedset the guide rail is not fixed. It can be moved and is there to be moved. That means the guide rail itself has to be stable, straight and/or well bended in itself. The guide rail cannot be forced into position anymore by the brackets.

This is a major difference in thinking which should not be underestimated.

The guide rail needs to be positioned with a higher accuracy than generally speaking is done with fixed guide rails, because you want small tolerances on the different relative positions. That means you also need smaller tolerances on the absolute positioning.

With the usual fixed side guide it's less important how accurate the brackets are positioned relative to the clamps on the guide rail. Especially when using a bracket with swivel head it can always be made to fit. With Speedset however the clamps and brackets need to be aligned properly to ensure smooth movement of the Speedset units when changing the position of the guide rail. See also under "position of the Speedset units".

Obviously when adjusting the guide rail on 1 side, it's also very important that the opposite fixed side is stable, straight and/or well bent and accurately positioned.

We do not recommend the use of 65 mm travel distance in combination with the 75 mm sleeve.

Using that combination leaves very little room for the QPC spacer hanging around the Speedset unit in the first –outer- position.

Please contact technical support if you need the 65 mm travel distance but you have no room for the 125 mm sleeve.

Cleaning:

When a line equipped with Speedset gets cleaned, attention should be paid to proper rinsing. Especially foam cleaners have the tendency to get in between the outer –static- sleeve and the inner –adjustable- rod. When the system is rinsed properly the Speedset unit remains easy to move back and forth.

Once in a while some oil may be applied between the inner and the outer part of the Speedset unit to keep it moving easily.

Speedset can also be used for vertical setting of a top guide. In this case attention should be paid to the weight of the guide relative to the strength of the spring. In certain special cases the Speedset unit may be adapted to a more heavy top guide. The spacer and the spring will then change position.

Roller side guides

For guiding packed products

Commonly where carton or shrinkfoil packed products are conveyed, a roller side guide is recommended to reduce the risk of damaged packaging material.

When an LBP chain or belt is used also the side guide needs to be a roller guide to make sure the friction on the side of the pack is not higher than underneath the pack.

There are different roller guide systems for both side and centre guide:

- full plastic
- aluminium
- stainless steel

For full details we refer to the components catalogue.

There are two special executions:

Speedrail aluminium rail with bead rollers.

The pearl shape of these rollers is particularly suitable for shrink foil packs:



There's also a completely flexible execution that allows a flexible radius or a twisted roller guide.

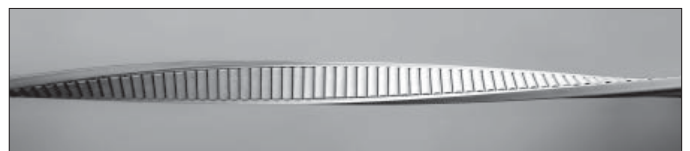
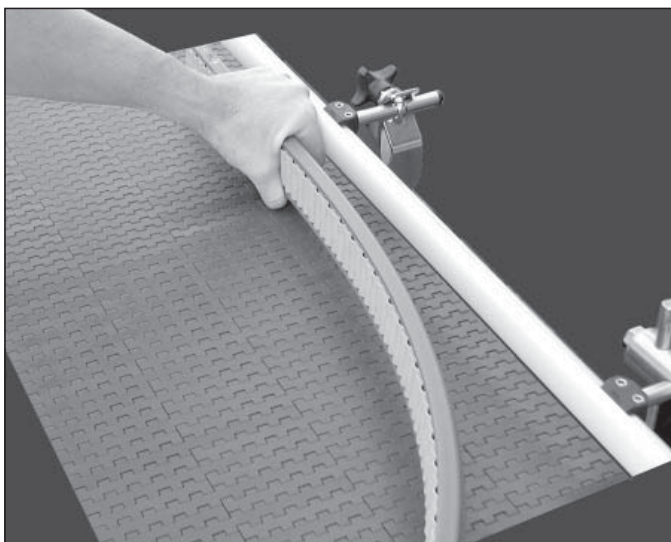

Muscle rail:

Muscle rail is a compact stainless steel execution particularly suitable in hygienic circumstances and where rigidity is requested.

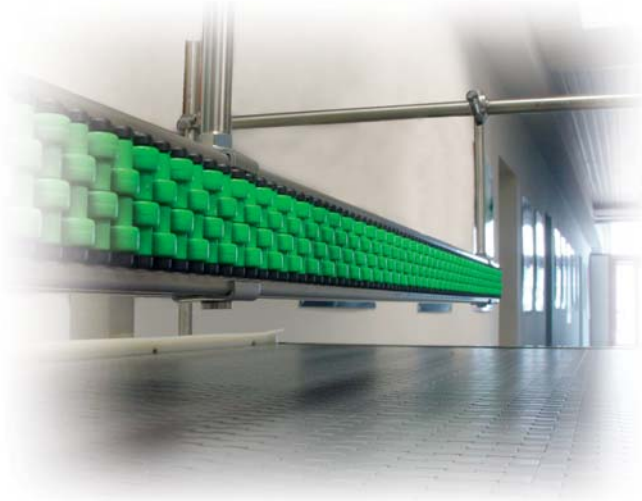

Important points:

- Make sure the roller guide is mounted in line with the pack (mostly vertical) so all rollers are in contact with the pack and the pressure is spread.
- Make sure the rollers touch the pack where the pack has enough stability. This is especially important with shrink wrapped packs of soft drink cans.
- Make sure both side guides are positioned accurately relative to the pack. Then the pack does not get the chance to rotate and increase the pressure on the side guide.
- Make sure the construction holding the intermediate guide is stable enough to keep the roller guide vertical.
- Make sure the individual lengths are mounted in line with each other to avoid little 'steps'.
- Make sure curves are made in a constant radius to get an even pressure on the side guide thru the curve.
- Make sure the distance between bridge elements supporting the roller side guides is short enough to avoid inadmissible bending.

Steel chain materials

C45

Carbon Steel

This carbon steel material allows a higher yield load capability than stainless steel but is not corrosion resistant, so only suitable for dry environments.

The through hardened plate material provides for a uniform hardness.

Features: • Surface hardness: 44 HRC **Benefits:** • High mechanical strength
• High abrasion resistance

STANDARD

Standard Stainless steel

AISI 430 Stainless steel material with good mechanical characteristics and corrosion resistance. An economical option for many conveying applications. Lower load and lower wear resistance capability than our higher grade stainless steel materials.

Features: • Standard stainless steel **Benefits:** • Economic solution

EXTRA PLUS

Extra Plus Stainless Steel

High performance stainless steel, specially developed for high speed and heavy duty application. Offers excellent corrosion resistance and highest surface hardness.

Features: • Surface hardness of HRC 26-30
• Extremely flat and best surface finish
• High corrosion and wear resistance
• Highest ultimate yield loading capability

Benefits: • Typically used in glide liners and pressureless combiners and very long conveyors.
• For improved product stability

AUSTIC

Austenitic Stainless steel

AISI 304 Austenitic stainless steel which offers high corrosion and acid resistance properties.

Features: • Stainless steel with 18% chrome and 8% nickel
Benefits: • High corrosion and acid resistance material

Pin materials for steel & plastic chains

SPM

Standard PIN Material

Special Austenitic stainless steel with higher tensile strength and improved surface hardness. These pins are offered as standard in most stainless steel and plastic chains.

Features: • High wear, corrosion and acid resistance
Benefits: • Longer wear life

HB

Special PIN Material

Vacuum hardened stainless steel with exceptionally high wear resistance characteristics, good corrosion and chemical resistance, for high speed and or abrasive applications.

Benefits: • Ultimate abrasion resistance
• Outstanding wear life

PPM

Plastic PIN Material

Special reinforced acetal resin.

Benefits: • Suitable for metal detectors
• Easy disposal of chains after use

Plastic chain materials

D

Acetal Resin

It is an acetal based material which is used as an economical alternative to our LF acetal material. Acetal is an ideal material for conveyor chains as it offers high tensile + fatigue strengths, good co-efficient of friction and excellent wear resistance properties.

W

Colour: Grey (D) or White (W)

This material is FDA (Food and Drug Administration) approved for direct contact with food.

LF

Low Friction Acetal Resin

This material is commonly used in the market and offers an improved co-efficient of friction. It is also suitable for use in high speed applications.

LFG

Colour: Light Brown (LF), Dark Grey (LFG) or White (LFW)

LFW

This material is FDA (Food and Drug Administration) approved for direct contact with food.

XPG

Extra Performance

Extra performance Acetal with additives for an even lower co-efficient of friction than LF materials. Suitable for high speed applications and reduced lubrication.

Colour: Dark Brown (XPG)

This material is FDA (Food and Drug Administration) approved for direct contact with food.

NG

New Generation

Extra performance PBT with lowest coefficient of friction in our range, resulting in good strength and optimum wear resistance, reduced plate wear and reduced pitch elongation. Suitable for high speed and dry running applications. Available exclusively from System Plast.

NGG

Colour: Green (NG) - Light Grey (NGG) - Dark Grey (NGD)

NGD

This material complies with Directive 2002/72/CE of August 6, 2002 related to materials destined to direct contact with food. Besides it respects the 'Code of Federal Regulation' as published by the Food and Drug Administration (FDA)

Special plastic chain materials

On request and for adequate quantities chains may be produced in other materials such as:

AS

Anti-static acetal resin

Anti-static material with improved surface conductivity for greater protection against static electrical discharges. **Colour:** Black (AS)

HT

High temperature resistance

High temperature material for applications up to 140°C.

CR

Chemical resistance

Reinforced polypropylene material for greater acid and chemical resistance. Polypropylene has lower mechanical strength than acetal.

Colour: White (CR, for chains)

AR

Abrasion resistance

Special wear resistant polyamide resin with improved abrasion resistance characteristics for conveying abrasive products like glass, cast iron.

Colour: Black (AR)

DK

Acetal resin with Delrin® Kevlar®

This material offers reduced friction and improved wear resistance compared to standard acetal. **Colour:** Dark grey (DK)

Delrin® and Kevlar® are registered trade marks of DuPont™

Plastic belt materials

LFG

Low Friction Acetal Resin

This material is commonly used in the market and offers an improved co-efficient of friction. It is also suitable for use in high speed applications.

Colour: Dark grey (LFG)

This material is FDA (Food and Drug Administration) approved for direct contact with food.

NGG

New Generation

Extra performance PBT with lowest coefficient of friction in our range, resulting in good strength and optimum wear resistance, reduced plate wear and reduced pitch elongation. Suitable for high speed and dry running applications. Available exclusively from System Plast.

Colour: Light Grey (NGG)

This material complies with Directive 2002/72/CE of August 6, 2002 related to materials destined to direct contact with food. Besides it respects the 'Code of Federal Regulation' as published by the Food and Drug Administration (FDA)

Special plastic belt materials

On request and for adequate quantities belts may be produced in other materials such as:

AS

Anti-static acetal resin

Anti-static material with improved surface conductivity for greater protection against static electrical discharges. **Colour:** Black (AS)

XPG

Extra Performance

Extra performance additivated Acetal with a lower co-efficient of friction than LF materials. Suitable for high speed applications and reduced lubrication. **Colour:** Dark Brown (XPG)

PP

Chemical resistance

Polypropylene material for greater and chemical and temperature resistance. Polypropylene has lower mechanical strength than acetal. For belts (PP) the pins and clips are also made of Polypropylene. **Colour:** Light Brown (PP)

DK

Acetal resin with Delrin® Kevlar®

This material offers reduced friction and improved wear resistance compared to standard acetal. **Colour:** Dark Grey (DK)

Delrin® and Kevlar® are registered trade marks of DuPont™

HT

High temperature resistance

High temperature material for applications up to 140°C.

Special colours

On request and for adequate quantities chains and belts may be produced in other colours.

Pin materials for belts

PBT

PBT

Most commonly used pin material in System Plast belts. It is used in all belts made of LFG, XPG, AS and DK acetal material. The combination of these materials offers a low noise operation.

POM

POM

Polyacetal pins are used in all belts made of NGG material. This pin material gives optimum strength.

PP

PP

Polypropylene pins are used in all belts made of PP material. The pin material is adapted to the high temperature and high chemical resistance of the belt material.

Rubber materials

TPR

TPR

TPR is used for VG chains and belts and for some gripper chains. TPR is a SEBS type rubber, which assures an optimum bonding on the plastic base material.

NBR

NBR

NBR rubber is used for our gripper chains. It offers a soft grip and a good resistance against oils.

EPDM

EPDM

EPDM rubber is used for our gripper chains. It offers good weather and chemical resistance, although contact with oils, gasoline and concentrated acids must be avoided.

EPDM-PP

EPDM-PP

EPDM-PP rubber is used for our gripper chains. It offers improved chemical resistance and can be used at higher temperatures. Resistance against steam is good.

Nolu-Clean

An antimicrobial material for improved hygiene for a range of plastic chains, belts and conveyor components.

Hygiene has become an important issue in a number of areas in filling and packaging lines. To support the effectiveness of your cleaning efforts, System Plast offers the possibility to use Nolu-Clean with chains and a range of components.

Growth inhibition test

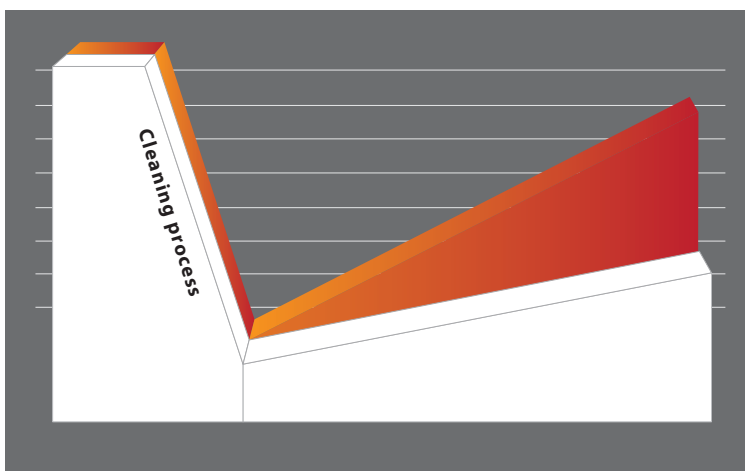

- Bacterial growth with Nolu Clean effect
- Normal bacterial growth after cleaning

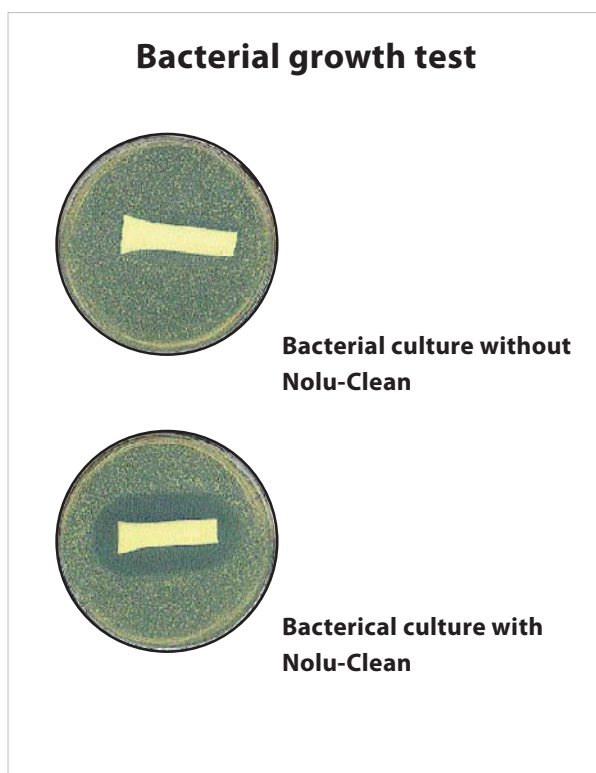

Features:

- Provides odor control and hygiene maintenance.
- Durable
- Inhibits growth of: Bacteria, Molds, Yeast
- Listed for industrial use in: Europe, Australia, Canada, China, Japan, Korea, Philippines, USA, Japan

- Plastic chains
- Modular belts
- Flange bearings
- Brackets
- Other products on request.

Ask your System Plast contact for availability.

Nolu-S

What is Nolu-S?

- Nolu-S material is a unique compound of UHMWPE and a solid lubricant.
- Drastically reduces the coefficient of friction, whilst maintaining the characteristics of UHMWPE.
- Nolu-S has a better thermal conductivity compared to UHMWPE.

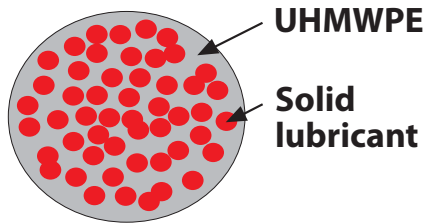

Nolu-SR:

For applications that require even higher wear resistance than Nolu-S already offers. Nolu-SR is a further improvement of Nolu-S

Nolu-S products:

Available for:

- Curves and straight tracks
- Side guides
- Extrusion profiles
- Wear strips

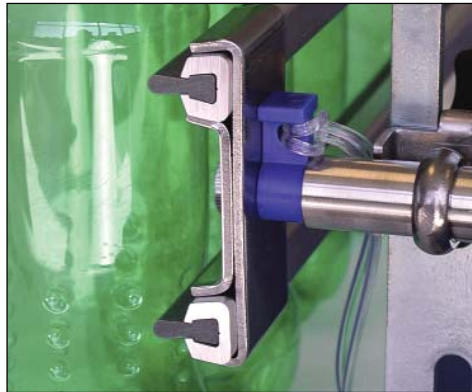

Nolu-S advantages:

Nolu-S reduces chain pull and avoids problems of overload in curves.

Other advantages of Nolu-S:

- Noise reduction
- Reduction chainpull- Longer chainlife
- Reduction chainpull - Reduced energy consumption
- Reduced stick-slip
- FDA approved base material and additives
- Suitable for running dry at higher speed

Wear rates comparison chart (NG)

The diagrams show the wear rate in 0/00 over the test duration in h.
 Test performed under dry run conditions.

Tested with 1.5 l PET bottles

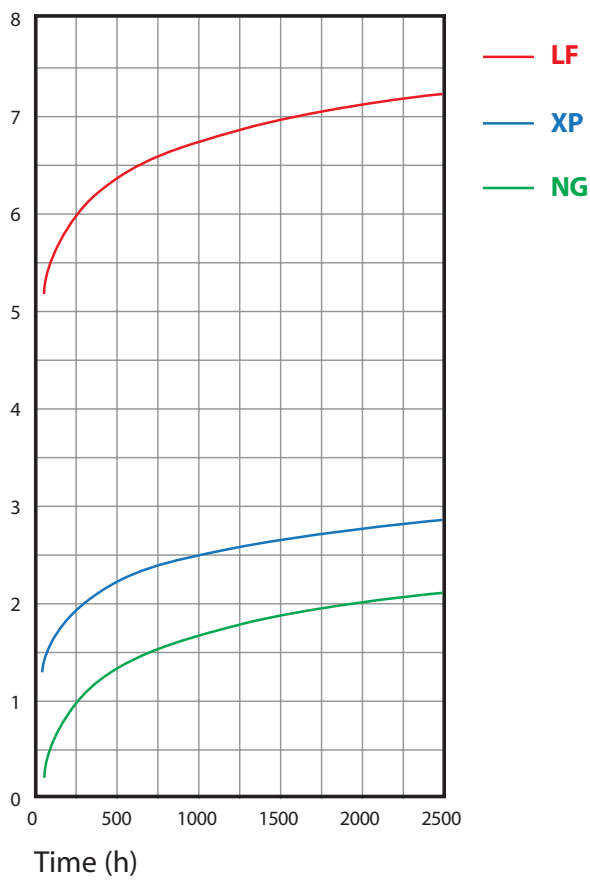

Tested with 1 l glass bottles

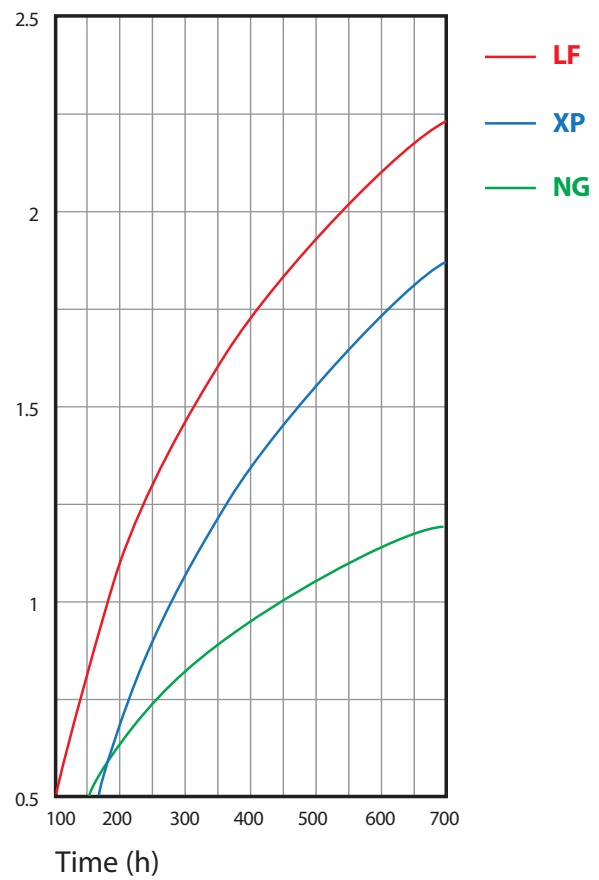

Test station

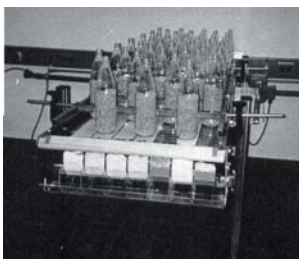

HB pins

Pin wear is a major factor regarding chain elongation.

Due to their extraordinary hardness HB pins offer a much better resistance against mechanical/abrasive wear and thus extended service life of chain.

HB pins are recommended for the following operating conditions and applications:

- Abrasive environment
e.g. crate and bottle conveyors
- Short conveyors running at high speed
e.g. filler area, inspector sections, pressure less combiners
- High load applications
e.g. accumulation area, full crate conveyors, full bottle accumulation tables

For material characteristics see page 93.

RoHs

Since System Plast does not produce, sell or re-sell electric or electronic equipment/components. Basically RoHs regulations 2002/95/CE and subsequent modifications do not apply. Besides, our products contain (much) less of the elements mentioned in these regulations than the limits mentioned in these regulations.

Storage of plastic chains and belts

- Materials of our plastic chains and belts offer best stability and resistance against environmental effects at appropriate storage:
 - in the original packaging,
 - without environmental radiation / UV light,
 - dry
 - in a non aggressive environment
 - a temperature between 5°C and 35°C
- First IN, first OUT.
We have applied that procedure in our logistic department.
We recommend this procedure to any external warehouse.
- Do not stack pallets or other heavy goods on top of chain packs. Chains inside the packs might get damaged.
- Do not stack chain packs higher than the original stacking height – as dispatched from our shipping department.

Coefficients of friction

Below listed coefficients can be used as a guideline. Dependent on environmental and application requirements (temperatures, lubricant, material combinations, dirt/debris, product and chain/belt surfaces, etc.) the coefficients are subject to variation.

Coefficient of friction between chain and wearstrip:

Chain/belt material	Lubrication	Wearstrip material				
		Stainless steel Steel	UHMWPE PA	NOLU-S	Return roller	Extra With metal strip for
Stainless steel, steel	Dry		0.35	0.32	0.10	not applicable
	Water	0.40	0.27	0.24	0.08	
	Water&soap	0.20	0.18	0.15	0.05	
	Oil	0.20	0.18	0.15		
LF- Acetal	Dry	0.24	0.20	0.18	0.10	0.19
	Water	0.19	0.16	0.14	0.08	0.15
	Water&soap	0.15	0.10	0.10	0.05	0.10
	Oil	0.10	0.10	0.10		
XPG- Acetal	Dry	0.22	0.18	0.16	0.10	0.17
	Water	0.18	0.14	0.13	0.08	0.14
	Water&soap	0.15	0.10	0.10	0.05	0.10
	Oil	0.10	0.10	0.10		
NG - PBT	Dry	0.20	0.16	0.13	0.10	0.14
	Water	0.17	0.11	0.09	0.08	0.10
	Water&soap	0.14	0.09	0.08	0.05	0.09
	Oil	0.10	0.10	0.10		
PP	Dry	0.29	0.24	0.21	0.10	0.23
	Water	0.23	0.19	0.17	0.08	0.18

Valid for ambient temperature (21°C)

Coefficient of friction between chain and product:

Chain/belt material	Lubrication	Product material					
		Paper carton	Metal (steel)	Aluminium	Plastics incl. PET	Glass (return)	New glass, ceramics
Stainless steel	Dry	0.40	0.50	0.35	0.30	0.47	0.35
	Water		0.35	0.30	0.25	0.31	0.30
	Water&soap		0.20	0.15	0.15	0.21	0.15
Speed-Line	Dry	0.40	0.45	0.32	0.27	0.40	0.29
	Water		0.30	0.27	0.23	0.26	0.24
	Water&soap		0.15	0.14	0.13	0.18	0.13
LF- Acetal	Dry	0.28	0.25	0.25	0.21	0.24	0.20
	Water		0.20	0.18	0.16	0.18	0.15
	Water&soap		0.15	0.14	0.13	0.14	0.12
XPG- Acetal	Dry	0.23	0.20	0.20	0.18	0.20	0.15
	Water		0.18	0.15	0.14	0.15	0.13
	Water&soap		0.15	0.13	0.12	0.12	0.12
NG - PBT	Dry	0.20	0.18	0.15	0.13	0.14	0.12
	Water		0.16	0.14	0.12	0.13	0.12
	Water&soap		0.13	0.12	0.10	0.11	0.10
LBP	Dry	0.10	0.10	0.10	0.10	0.10	0.10
VG	Dry	0.60	0.73	0.50	0.50		0.50
PP	Dry	0.40	0.30	0.32	0.28	0.29	0.26
	Water		0.24	0.26	0.22	0.23	0.21

Valid for ambient temperature (21°C)

Chemical resistance

Data shown in the table was taken from laboratory tests performed on unstrained samples and are merely indicative.

Chemical resistance under normal working conditions can depend on various factors, such as stress and temperature, concentration of the chemical agent and duration of its effects.

Valid for ambient temperature (21°C)

Chemical agent	METALS				PLASTICS						RUBBERS																	
	EXTRA	AISI 304	AISI 316	OT.NI	POM	PBT	PP	PA	PE	EPDM	NBR	SEBS	VITON															
	C %	C %	C %	C %	C %	C %	C %	C %	C %	C %	C %	C %	C %															
Acetic Acid	5	☆	20	☆	100	☆		○	5	●	10	☆	40	☆	10	●	10	☆	25	☆		●	25	○	20	●		
Acetone		☆	25	☆				☆		○				☆	100	☆			☆		☆		●		○		●	
Acrylonitrile														☆	100	☆				☆		●		○		●		
Aluminium chloride				○	10	○								○	10	☆				☆		☆		☆	☆	SA	☆	
Aluminium sulphate					SA	☆								☆	10	☆				☆		☆		☆	☆	SA	☆	
Amyl alcohol				☆		☆					☆			☆	10	☆				☆				☆		☆	☆	
Ammonia		☆	100	☆		☆		●	☆		○	30	☆	10	☆				☆		○		○		○	○		
Ammonium chloride				○		☆						10	☆	10	☆				☆		☆		☆	☆	SA	☆	☆	
Aniline		☆		☆		☆								☆	100	○	3	☆		●		●		●		☆	☆	
Barium chloride				○	SA	☆								☆	10	☆				☆		☆		☆	☆	☆	☆	
Beer		☆		☆		☆			☆					☆		☆				☆		☆		☆	☆	☆	☆	
Benzene		☆	70	○		☆			☆		●			☆					○		●			●		☆	☆	
Benzoic acid			100	☆	SA	☆					☆	SA	☆	SA	○				●		☆		●		●	☆		
Benzol				☆		☆			☆		☆			○	100	☆				○	●		●		●		○	
Boric acid			○	SA	☆		☆					10	☆	SA	☆	10	☆	SA	☆		☆		☆		☆	SA	☆	
Brine	10	●		○		☆								○		○				☆		☆		○		☆	☆	
Butter				☆		☆			☆		☆			☆		☆				☆		☆		☆	○		☆	
Butyl acetate						☆						○		○	100	☆					○			○		●	☆	
Butyl alcohol				☆										☆	100	☆					☆		○		☆		☆	
Butyl glycole						☆								☆	100	☆					☆			☆		☆	☆	
Calcium chloride		●		○		☆			☆			50	☆	10	☆	SA	☆			☆		☆		☆	SA	☆	☆	
Carbon sulphide				☆		☆								☆	100	☆					●		●		●		☆	
Carbon tetrachloride			10	☆		☆			☆					●		☆					●		●		●		☆	
Chlorine water		●		●		○								●						●		3	○		3	○	☆	
Chloroform		○	10	☆		☆			☆					○	100	●				●		●		●		●	☆	
Chromic acid			25	☆	50	○								1	○						50	○	●	50	●	50	☆	
Citric acid	10	☆		☆	SA	☆		●	○	10	☆	10	☆	10	○					☆		☆		☆	SA	☆	☆	
Cyclohexane						☆								☆	100	☆					●		☆		●		☆	
Cyclohexanol						☆								☆	100	☆					●		☆		○		☆	
Decalin						☆								○	○						●		○		●		●	
Dioxane						☆								☆	○						○		●		●		☆	
Distilled water		☆	10	☆		☆			☆					☆		☆				☆		☆		☆		☆	●	
Ethyl acetate				○		☆								○		☆						●		●		○	☆	
Ethyl alcohol				☆					☆			96	☆	96	☆						○		○				☆	
Ethyl chloride				☆					○					●	100	☆					○		○				●	
Ethyl ether						☆								☆	100	☆											☆	
Ferric chloride				○		☆								10	☆						☆		☆		☆	SA	☆	
Food fats		☆	100	☆		☆			☆						☆					○		☆		○			☆	
Food oils		☆		☆		☆			☆					☆		☆					☆		☆		☆		☆	
Formaldehyde		☆		☆		☆			☆				40	☆	30	☆					○		○		○	40	●	
Formic acid	2	○		●	100	☆		☆	10	●				○	10	●	10	●		☆		☆		☆		○	☆	
Freon 12				☆										☆							☆		☆				☆	
Fresh water		☆		☆		☆			☆					☆		☆				☆		☆		☆		☆	☆	
Fruit juice		☆		○		☆			☆					☆		☆				☆		☆		☆		☆	☆	
Gasoline		☆		☆		☆			○					○	☆					●		○		●			☆	
Glycerine		☆		☆		☆			☆					☆		☆					☆		☆		☆		☆	
Hydrochloric acid		●		●		●		○	35	●	20	○	30	☆		●	35	☆		15	☆		○	15	☆	37	☆	
Hydrofluoric acid				●		●							40	☆		●	70	☆			●		●		●		48	☆
Hydrogen peroxide	3	☆		☆	100	☆									●					30	○		●	30	●	90	☆	
Isopropyl alcohol						☆								☆		☆				☆		☆		☆		☆	☆	
Lactic acid			○			☆		●	☆	10	☆	20	☆		☆					○		☆		○			☆	
Linseed oil				☆		☆			☆					☆		☆				○		☆		●			☆	

Chemical agent	METALS				PLASTICS						RUBBERS								
	EXTRA	AISI 304	AISI 316	OT.NI	POM	PBT	PP	PA	PE	EPDM	NBR	SEBS	VITON						
	C %	C %	C %	C %	C %	C %	C %	C %	C %	C %	C %	C %	C %						
Magnesium chloride			○	☆				☆	☆			☆	☆		☆	SA	☆		
Methyl acetate			○	☆				○	☆			○	●		●		●		
Methyl alcohol		80	☆	☆	☆		☆					☆	○		☆		○		
Methylene chloride		○		○	☆			●	●	○	☆	○	●	●	●		○		
Milk		☆		☆	☆	☆		☆	☆	☆	☆	○	☆		☆		☆		
Mineral oil				☆	☆			☆	☆	☆	☆	●	☆		●		☆		
Nitric acid	25	○	65	☆				☆		●	○		10	●			70	☆	
Nitrobenzene				☆					☆	☆	○		●	●	○		○		
Oleic acid		○		☆	☆			☆	☆	☆	○		●	○	○		○		
Oxalic acid			65	☆	☆			10	☆	☆	○		○	○	○		☆		
Paraffin				☆				☆	☆			☆	○			●			
Petroleum			☆	☆	☆	☆		☆	☆	☆	☆	●	●	☆	●		☆		
Petroleum ether			☆	☆	☆	☆		○	☆	☆			●	●	●		☆		
Phenol			☆	☆				●	☆	●			○	●	○		☆		
Phosphoric acid	25	○		●	☆	●	●	●	☆	●	☆		☆	20	○		☆	85	☆
Potassium bichromate				SA	☆				○	☆			☆		○	○	SA	☆	
Potassium bromite					☆			☆	☆	☆			☆		☆		☆		
Potassium hydroxide	☆	50	☆	☆	☆	●	●	☆	☆	☆	☆		☆	○		☆	☆		
Potassium permanganate			☆	☆				☆	☆	●			10	☆	●	10	○	☆	
Sea water		●	☆	☆	☆	☆	○	☆	☆	☆	☆	☆	☆	☆	☆	○	☆		
Silicone oil				☆				☆	☆	☆			☆	☆	☆		☆		
Silver nitrate			○	☆					☆	☆				○			☆		
Sodium carbonate		☆	100	☆	SA	☆		☆	10	☆	☆	☆	☆	☆	☆	☆	☆		
Sodium chloride		○		○	☆	☆		☆	☆	☆	☆	☆	☆	☆	☆		SA	☆	
Sodium hydroxide	40	☆		☆	60	☆		10	●	☆			☆	○	☆		☆		
Sodium hypochlorite			●	SA	○	●	10	○	☆	☆	☆		10	☆	●	10	○	5	☆
Sodium silicate			100	☆	☆					☆			☆	☆	☆		☆		
Sodium sulphate			100	☆	☆					☆			○	☆	☆		☆		
Soft drinks			☆	☆	☆	☆		☆	☆	☆	☆	☆	☆	☆	☆		☆		
Suds			☆	☆	☆	☆	10	☆	☆	☆	☆	☆	☆	☆	☆		☆		
Sulphuric acid	●	●	●	○	☆	●	2	☆	☆	●	○	50	☆	●	50	○	95	☆	
Tartaric acid	☆	50	☆	☆	☆	●	○	50	☆	☆	☆	☆	○	☆	☆		☆		
Tetrahydrofuran				☆				☆	○	☆			●	●	●		●		
Tetralin			●	☆	☆			☆	●	☆			●	●	●		☆		
Tincture of iodine			○	☆	●				☆	●	☆		○	●	○		☆		
Toluol		☆		☆				☆	☆	☆			●	●	●		○		
Transformer oil		☆		☆				☆	○	☆			●	☆	●		☆		
Trichloroethylene			●	100	☆			●	○	○			●	●	●		☆		
Triethanolamin				☆				☆	☆	☆			○	●	○		●		
Turpentine	☆	☆	☆	☆		●	☆				●		●		●		☆		
Vaseline				☆				☆	☆		☆		○	●	☆		●	☆	
Vegetable juice	☆	☆	☆	☆	☆	☆		☆	☆	☆	☆	☆	☆	☆	☆		☆		
Vegetable oils	☆	☆	☆	☆	☆	☆	●	☆	☆	☆	☆	○	☆		○		☆		
Vinegar	☆	☆	☆	100	☆	☆	☆	10	☆	☆	☆	☆	25	☆	○	25	○	●	
Water and soap	☆	☆	☆	☆	☆	☆		☆	☆	☆	☆	☆	☆	☆	☆		☆		
Whisky	☆	☆	☆	☆	☆	☆		☆	☆	☆			☆	☆	☆		☆		
Wine	☆	☆	☆	☆	☆	☆		☆	☆	☆	○		☆	☆	☆		☆		
Xilol	☆	☆	☆	☆	○	●		☆	●	☆	☆		●	●	●		☆		

ABBREVIATION

C = concentration
SA = saturated

☆ = good resistance
● = insufficient resistance (not recommended)

○ = fairly good resistance depending on use conditions
blank spaces = no tests performed

Application temperatures

Material	Symbol	User for	Min temp. °C	Max. temp. °C	
				Dry	Wet
Carbon steel	C45	Steel chains, roller chains	-70	180	not recommended
Ferritic stainless steel	Standard	Steel chains	-30	400	130
Extra stainless steel	Extra	Steel chains	-30	400	130
Extra plus stainless steel	Extra plus	Steel chains	-30	400	130
Austenitic stainless steel	Austic	Steel chains, roller chains	-30	400	130
Acetal resin	D,W	Plastic chains	-40	80	65
Low friction acetal resin	LF (all colors)	Plastic chains and belts	-40	80	65
Extra performance acetal resin	XPG	Plastic chains and belts	-40	80	65
Anti static acetal resin	AS	Plastic chains and belts	-40	80	not applicable
Delrin kevlar	DK	Plastic chains and belts	-40	80	65
New generation	NG (all colors)	Plastic chains and belts	-40	120	60
Polypropylene	PP	Plastic chains and belts	0	104	104
Chemical resistant	CR	Plastic chains	0	104	104
High temperature resistance	HT	Plastic chains and belts	0	140	140
Abrasion resistant	AR	Plastic chains	0	90	90
Thermoplastic rubber SEBS	TPR	VG chains and belts, gripper chains	-40	100	100
NBR rubber	NBR	Gripper chains	-25	100	100
EPDM rubber	EPDM	Gripper chains	-40	120	120
EPDM-PP rubber	EPDM-PP	Gripper chains	-40	120	120
Polyamide	PA	Sprockets, components	0	90	90
Polyamide reinforced	PA FV	Sprockets, bearing, components	0	90	90
Polypropylene	PP	Components	0	104	104
Polypropylene reinforced	PP FV	Bearing, components	0	104	104
Polyethylene	PE	Curves, components	-40	80	80
Nolu-S	Nolu-S	Curves, components	-40	80	80

If a chain, belt or other component is composed of several materials, all materials will have to be considered individually.

Please note that the properties of a material changes when the temperature changes.

In general the impact resistance becomes less at low temperatures.

The strength and wear resistance are reduced at elevated temperatures.

High temperatures can also influence the resistance against chemicals.

In case of doubt please consult our Technical Support department.

Parameters affecting wear rate

Operating conditions:

- Load
- Speed
- Number of starts per hour
 - No soft start/frequency inverter controlled drive
- Product accumulation
- Lubrication
- Water quality
 - Concentration of chlorines
 - Water hardness
 - Contaminations
 - Discontinuous water supply
- Lubricant
 - Suitability/performance
 - Dosing
 - Efficiency of nozzles

Cleaning:

- Cleaning agent
 - Frequency
 - Intensity
 - Rinsing
 - Concentration
 - Temperature
- Chemical attack

Environment:

- Temperature
- Humidity
- Wear increasing media/abrasives
- Corrosion
- Cleanliness
 - Soil e.g. from construction work

Conveyor components:

- Material quality
- Construction
- Dimensional accuracy of
 - Wear strips
 - Sprockets
 - Idlers
 - Return rollers
- Shaft alignment

Conveyor construction:

- Choice of chain/belt
- Suitability of selected chain/belt for the application
- Catenary design
 - Tensioner
- Sprocket construction
 - Tooth geometry
 - Number of teeth/polygon effect
- Return part construction
 - Smooth infeed
 - Non rotating return rollers
- Mounting of wear strips
 - Flatness
 - Chamfers
 - Raised portions
 - Expansion compensation gaps

Changed/modified conditions:

- Modification of conveyor or it's parts/components
 - Maintenance
 - Overhaul

Cleaning instructions

Cleaning is necessary to:

- minimize dirt and debris built up
- keep bacteriological situation under control
- elongate service life of chains/belts
- ensure smooth running of chain/belt for optimum product stability
- prevent crashes due to f.e. glass debris
- prevent malfunction due to sticky residues
- keep friction low

Frequency:

As a rule of thumb we say that cleaning the line once every week is sufficient.

Of course in practice depending on the circumstances this can be more frequent (f.e. during product changes in case of product loss or other pollution) or less frequent in a relatively clean environment.

In the direct surrounding of the filler cleaning will be more frequent anyway. Depending also on the bacteriological situation it may be necessary to clean at least once a day or once every shift.

Also chemicals coming f.e. from a pasteurizer may ask for more frequent cleaning to prevent the chemicals from affecting the chain/belt materials.

In a can line where aluminium cans are filled, there's the aluminium oxide that has to be kept under control. This can occur also far away from filler-pasteurizer, where the line is running dry. When the cans are accelerating on an inliner the remaining drops will fall down with the aluminium oxide on the chain causing a highly abrasive sludge to built up on the inliner. Therefore it may be necessary to clean more frequent also further down the line due to 'local' circumstances.

Method:

Important for an optimum service life of the chains and belts is a general inspection on the conveyors already during operation. Listen for strange –rattling or squeaking- noises. Check transfer plates, return rollers, bearings, etc. Make sure the chain/belt is still running free without extra load or obstruction.

Often the service life of a chain/belt is reduced for mechanical reasons that can be sorted easily.

When cleaning we advice to go thru following steps:

1. Check for foreign parts on the conveyor. Check also the return part.
2. Rinse with warm (max 60°) or cold water thoroughly while chain/belt is running.
3. Use mild (PH-5-9) detergent according to suppliers instructions.
4. If necessary clean mechanically (brush) when pollution is hard to remove.
5. Rinse thoroughly with warm (max 60°) or cold water. Make sure all detergent is rinsed off while chain/belt is running.
6. Final mechanical check that chain/belt is running free and without obstruction.

During this process it's important not to forget to clean in between carry and return section and underneath where the return support system is.

Especially with plastic chains/belts the detergent in use needs to be checked for compatibility with the plastic materials of the chain/belt.

General:

As obvious as it seems, cleaning is important!

Since nowadays pressure on production rates and production costs is getting higher and higher, companies tend to look at cleaning when trying to cut costs.

Less time and resources are available while at the same time the capacity of the lines (and thus pollution and product loss) has to go up.

When companies are setting up a cleaning regime they tend to focus on the individual machines (mainly filler and surrounding) and not so much on the conveyors. Therefore we want to promote 'CONVEYOR AWARENESS' in this respect.

Dry versus wet:

When a wet lubricant is in use (water & soap) product loss is normally flushed off by the water & soap. Often the soap also has a 'cleaning function' built in.

But wet circumstances also attract dust and dirt and wet circumstances will increase the growth of bacteria.

When a line is standing still during a stop or during the weekend without cleaning, the lubricant will dry in which may cause pollution and changing sliding characteristics of the chains/belt after several times.

Under dry circumstances the conveyors generally remain cleaner. But product loss needs to be cleaned to avoid functional problems of the line.

Therefore functionally speaking wet lubrication is more safe but requires just as well regular cleaning and is a high cost factor.

All together with the present state of conveyor technology it is possible to run a major part of a glass, can or a PET line dry taken into consideration that a regular cleaning regime is in place.

Inspection procedure

1. Inspect chains for unusual wear patterns or damage.
2. Look for excessive gaps between chain flights.
3. Check conveying surface for flatness, bent or broken flights.
4. Inspect hold-down tabs or beveled sliding surfaces for excessive wear.
5. Review chain catenary sag for proper amount.
6. If take-ups are used, check that take-up tension is not excessive. Do not preload chain.
7. Check all idlers, rollers, turn discs and sprockets for freedom of rotation.
8. Examine sprockets for excessive wear.
9. Look for debris build up in sprocket tooth pockets.
10. Check for excessive guide ring wear.
11. Check all wear strips and fasteners for excessive wear.
12. Check all transfer points, dead plates, turn tables, turn discs and sprockets for proper elevation and alignment.
13. Review function of lubrication system.
14. Inspect general cleanliness of conveyor system.

Installation procedure

1. Check all sprockets, idlers, turn discs and rollers for proper elevation and alignment with regard to the conveyor tracks.
2. Check all wear strips (carrying and return), dead plates, dividers and transfers mechanism for proper location, elevation, spacing and flatness.
3. Check all fasteners for proper tightness (torque). Fasteners used on wear strips and dead plates must have recessed heads.
4. Check all conveyor splice points for proper elevation, alignment and fastening.
5. Inspect conveyor system for obstructions by pulling a short section of chain (1 metre) through the entire conveyor.
6. Check lubrication system (if present).
7. Install conveyor chain, assuring that the following has been done:
 - A. Check for correct direction of chain travel.
 - B. Assemble chain in 3 meters sections and avoid twisting or damaging the chain.
 - C. Connect chain sections on the conveyor. Make sure that the connecting pins are not protruding.
 - D. Adjust chain catenary (sag) to the proper elevation. Note: readjustment is usually necessary after a certain operating time.
8. Insure that lubricant is evenly dispersed through conveyor system.
9. Start up conveyor by jogging and/or using short running periods before loading the system.
Be alert to unusual noises or actions. If a problem should occur, refer to the trouble shooting guide.

To help inserting the pin use our chain mounting block.

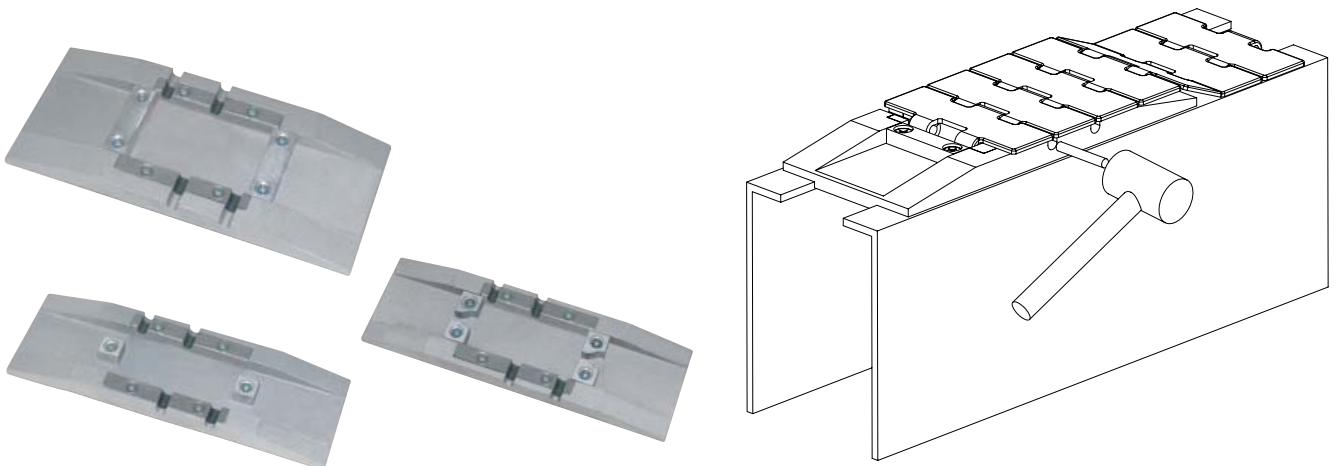

Replacement criteria

Chains must be replaced when:

- The chain starts to jump on the sprocket due to elongation. This may start to happen at 3% elongation or more.
- The thickness of the plate has been reduced by 50%.
- The surface becomes uneven or scratched causing stability problems.
- The hinge is worn to an extent that the pins protrude

Belts must be replaced when:

- The belt starts to jump on the sprocket due to elongation. This may start to happen at 3% elongation or more.
- The thickness of the module has been reduced by 1 mm from the top and from the bottom.
- The surface becomes uneven or scratched causing stability problems.

When replacing chains/belts, it is recommended to replace wear strips and sprockets/idlers as well.

Replacement of (magnetic) **corner tracks**:

Normal situation:
chain centered on the curve:

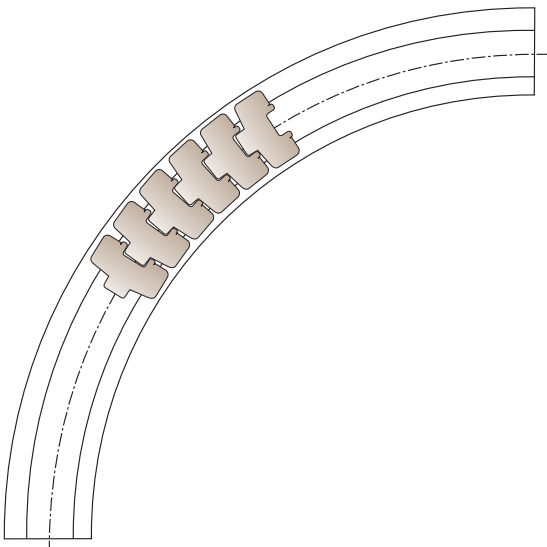

Worn curve:
chain over the inside edge:

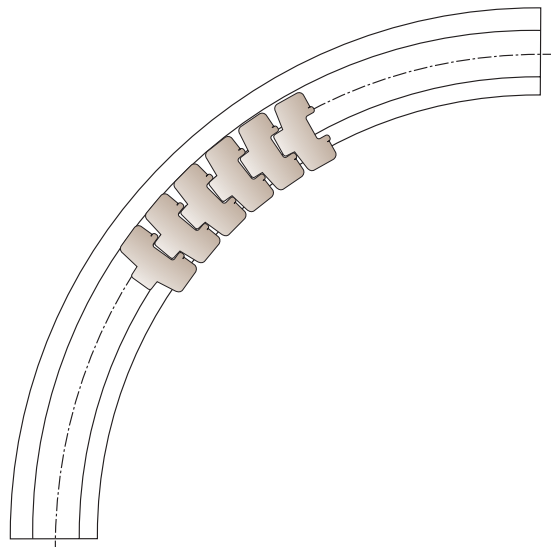

Sprockets and Idlers must be replaced when:

- teeth are worn flat
- chain/ belt does not release well
- teeth are damaged
- bore of idler is worn out and idler starts to oscillate
- hub or keyway are damaged
- new chain/ belt is installed

Wear strip must be replaced when:

- thickness is reduced by 50% and stability problems occur
- dirt or debris is embedded
- fixing bolts protrude

CLEANING AND MAINTENANCE

To be able to **identify a curve** following information is important:

- which type of chain and what width, f.e. 880M-K325
- angle α ; centre radius R ; straight lengths in/out L_{in}/L_{out}
- total width W and pitch P in case of multiple strand
- type of return;
- inserts; mounting hole, etc

See drawing:

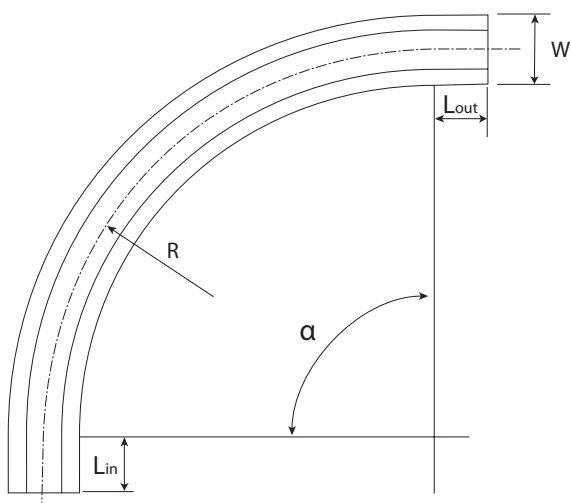

Check the thickness T of the upper part and for multiple strands measure the pitch P between the individual strands:

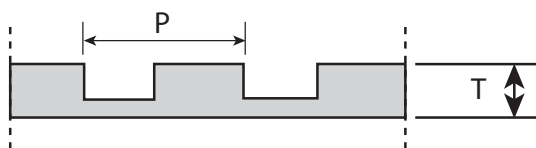

For the return section measure the thickness H and check whether the tracks are staggered:

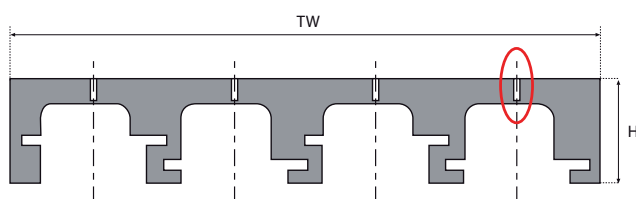

For special mounting holes or threaded inserts please provide a detailed drawing of the type and position.

Chain/belt jumps on sprocket

Possible causes	Remedy
Chain/belt is elongated e.g. due to wear or overloading	Replace chain/belt and sprocket. Check other components as well. Eliminate cause of overload.
Improper catenary sag	Check dimensions and adjust
Sprocket is worn	Replace sprocket
Wrong sprocket type	Install correct sprocket
Misaligned sprocket	Check and adjust
Improper sprocket position	Check and adjust position

Chain/belt does not release well

Possible causes	Remedy
Incorrect sprocket dimension or type	Check and replace sprocket
Sticky residue	Clean chain/sprocket or renew
Improper catenary sag	Check dimension and adjust

Slip stick operation

Possible causes	Remedy
Slip stick	Use lubrication. Reduce chain/belt tension by shortening the conveyor
Return roller diameter too small	Install larger rollers
Chain/belt catches the conveyor	Remove obstructions. Check return part as well
Improper catenary sag	Check dimension and adjust

Damaged chain hinges

Possible causes	Remedy
Overloading	Eliminate cause of overloading Check sprockets and other components Replace chain/belt Replace components if necessary
Blocking and obstructions	Check the complete conveyor
Exceeding the minimum backflex radius	Check conveyor construction
Too small radius for side flexing chain	Check minimum radius of chain and adjust accordingly

Elongation

Possible causes	Remedy
Overloading	Eliminate cause of overloading Check sprockets and other components Replace chain/belt Replace components if necessary
Wear from dirt in hinges	Improve cleaning Use HB pins

Rapid curve wear

Possible causes	Remedy
Overheating	Use EXTRA curve or Nolu-S
Embedded abrasives	Replace curve

TROUBLESHOOTING

Chain drifts sideways on sprockets

Possible causes	Remedy
Bad shaft/sprocket alignment	Adjust or use collars
Conveyors is not level	Adjust

Cracked hinge eyes

Possible causes	Remedy
Stress-corrosion caused by incompatible chemicals	Check chemicals compatibility with chain/belt material Use appropriate chemicals

Chains for magnetic system releases from curve

Possible causes	Remedy
Worn curve	Replace curve
Improper chamfering of the infeed or other obstructions	Check and adjust/rework
No soft start-up	Install frequency inverter drives
Curve not mounted level	Check and adjust

Corroded steel chain

Possible causes	Remedy
Incompatible combination of chain material and chemicals	Use only compatible chemicals
May occur even with stainless steel	Consider higher graded material

Excessive chain/belt wear

Possible causes	Remedy
Pollution	Improve cleaning
Failing lubrication	Check lubrication system Contact lubricant supplier
Obstructions	Check all sections
Debris in return part	Clean conveyor Install roller with larger diameter

Sprockets don't slide on shaft when belt extends due to temperature increase

Possible causes	Remedy
Pollution	Improve cleaning
Axial fixing incorrect	Re-adjust axial fixing according to temperature situation
Wrong bore tolerance	Replace by sprockets with PLUS tolerance

Rapid wear on sprockets

Possible causes	Remedy
Abrasive conditions	Improve cleaning Use steel sprockets

Please contact technical support at any time in case of doubt.

Catalogues available on request

System Plast

*Our complete range of components will cover
all your productive needs*

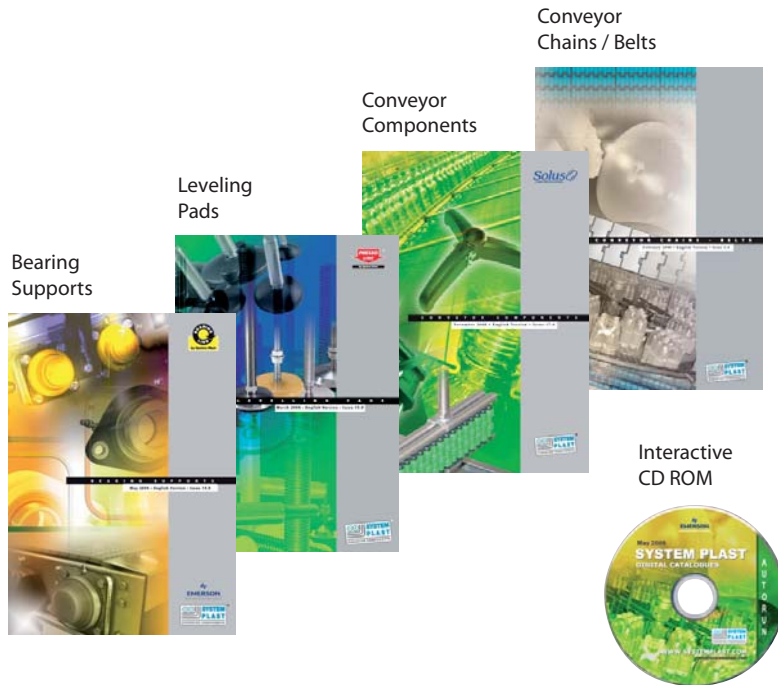

System Plast worldwide!

Local Commitment, Global Presence

System Plast can reach you everywhere with fast shipments of standard or customized products.
Find our agent or representative closest to you.



Contact us

To contact your local Technical Support check our website www.systemplast.com
or send an email to: technicalsupport@systemplast.com



www.systemplast.com

 **System Plast S.p.A. - ITALY**
24060 Telgate (Bergamo) - ITALY
Telephone 035.83.51.301
Telefax 035.83.51.406
info@systemplast.com

 **System Plast - GERMANY**
Tel. (03529) 56.15.0
Fax (03529) 51.13.67
info@fspchains.com

 **System Plast - GERMANY**
Sales Office - GERMANY
Tel. (06204) 9673.0
Fax (06204) 9673.29
info-de@systemplast.com

 **Sytem Plast s.a. - FRANCE**
Tel. (01) 64.66.05.48
Fax (01) 64.66.05.82
info-fr@systemplast.com

 **System Plast International
THE NETHERLANDS**
Tel. (0186) 63.61.21
Fax (0186) 63.61.25
info-nl@systemplast.com

 **System Plast - ENGLAND**
Tel. (01926) 614.314
Fax (01926) 614.914
info-uk@systemplast.com

 **Solus - USA - EAST**
Tel. (919) 775.5716
Fax (919) 775.5720
solusteam@solusii.com

 **Emerson Power Transmission
USA - WEST**
Tel. 866.765.8744
Fax 866.447.6587
solusteam@solusii.com

 **Solus System Plast - MEXICO**
Tel. (033) 3688-0024
Fax (033) 3688-0036
info-mx@systemplast.com

 **System Plast - BRAZIL**
Tel. (011) 3849.48.46
Fax (011) 3845.46.02
info-br@systemplast.com

 **System Plast - SINGAPORE**
Tel. (65) 6746.8990
Fax (65) 6745.1380
info-sg@systemplast.com

 **Emerson Power Transmission
(Zhangzhou) Co., Ltd. - CHINA**
Tel. (86) 596 2136017
Fax (86) 596 2136004
sales.zz@emerson.com